



MODULAR CUBER

PARTS LIST

[HE] [GENERAL(60Hz)] [KOREA] [HS]

E1CP

E1CP-D001, D002, D003, D004, D005, D006, D007, D008
-D009, D010, D011, D012, D013, D014, D015, D016
-D017, D018, D019, D020, D021, D022, D023, D024
-D025, D026, D100, D101, D102, D103, D104, D105
-D106, D107, D108, D109, D110, D120, D121, D122
-D123, D124, D125, D126, D200

A-1 SEP. 2011
B-1 JUN. 2012
B-2 SEP. 2012
B-3 OCT. 2012
C-1 FEB. 2013
G-1 APR. 2017
G-2 OCT. 2017
J-1 JUL. 2019
J-2 SEP. 2019
K-1 MAR. 2020
K-2 NOV. 2020
L-3 DEC. 2021

IM-240ANE
IM-240ANE-21
IM-240ANE-23
IM-240AWNE
IM-240AWNE-21
IM-240AWNE-23
IM-240AWNE-17
IM-240ANE(HS)
IM-240ANE-21(HS)
IM-240ANE-23(HS)
IM-240ANE(KR)
IM-240ANE-SN

List of Specifications

IM-240ANE	E1CP	Standard
IM-240ANE-23	E1CP-D001	23mm ICE of IM-240ANE
IM-240ANE-21	E1CP-D002	21mm ICE of IM-240ANE
IM-240AWNE	E1CP-D003	Water cooled
IM-240AWNE-23	E1CP-D004	For HE,23mm ICE of IM-240AWNE
IM-240AWNE-21	E1CP-D005	Water cooled, 21mm ICE, 50Hz
IM-240AWNE	E1CP-D006	230V,60Hz of IM-240AWNE
IM-240AWNE-23	E1CP-D007	For GENERAL 23mm ICE,230V,60Hz of IM-240AWNE
IM-240AWNE-21	E1CP-D008	For GENERAL 21mm ICE,230V,60Hz of IM-240AWNE
IM-240ANE	E1CP-D009	For GENERAL,230V,60Hz of IM-240ANE
IM-240AWNE-17	E1CP-D010	For KOREA 17mm ICE,220V,60Hz of IM-240AWNE
IM-240AWNE	E1CP-D011	SUS316 frame of IM-240AWNE
IM-240AWNE-21	E1CP-D012	For GENERAL, 21mm ICE,230V,60Hz, SUS316 frame of IM-240AWNE
IM-240ANE	E1CP-D013	SUS316 frame of IM-240ANE
IM-240ANE-23	E1CP-D014	23mm ICE,SUS316 frame of IM-240ANE
IM-240ANE-21	E1CP-D015	21mm ICE,SUS316 frame of IM-240ANE
IM-240AWNE-23	E1CP-D016	23mm ICE,SUS316 frame of IM-240AWNE
IM-240AWNE	E1CP-D017	For GENERAL 230V,60Hz,SUS316 frame of IM-240AWNE
IM-240AWNE-23	E1CP-D018	For GENERAL, 23mm ICE, 230V,60Hz, SUS316 frame of IM-240AWNE
IM-240ANE	E1CP-D019	For GENERAL 230V,60Hz,SUS316 frame of IM-240ANE
IM-240AWNE	E1CP-D020	For KOREA, 220V,60Hz of IM-240AWNE
IM-240AWNE-23	E1CP-D021	For KOREA 23mm ICE,220V,60Hz of IM-240AWNE
IM-240AWNE-21	E1CP-D022	For KOREA 21mm ICE,220V,60Hz of IM-240AWNE
IM-240ANE(HS)	E1CP-D023	For Singapore special water valve
IM-240ANE-23(HS)	E1CP-D024	23mm ICE for Singapore special water valve
IM-240ANE-21(HS)	E1CP-D025	21mm ICE for Singapore special water valve
IM-240ANE(KR)	E1CP-D026	For KOREA,220V,60Hz

List of Specifications *Stainless frame standard model

IM-240ANE	E1CP-D100	Standard
IM-240ANE-23	E1CP-D101	23mm ICE of IM-240ANE
IM-240ANE-21	E1CP-D102	21mm ICE of IM-240ANE
IM-240AWNE	E1CP-D103	Water cooled
IM-240AWNE-23	E1CP-D104	For HE,23mm ICE of IM-240AWNE
IM-240AWNE-21	E1CP-D105	Water cooled, 21mm ICE, 50Hz
IM-240AWNE	E1CP-D106	230V,60Hz of IM-240AWNE
IM-240AWNE-23	E1CP-D107	For GENERAL 23mm ICE,230V,60Hz of IM-240AWNE
IM-240AWNE-21	E1CP-D108	For GENERAL 21mm ICE,230V,60Hz of IM-240AWNE
IM-240ANE	E1CP-D109	For GENERAL,230V,60Hz of IM-240ANE
IM-240AWNE-17	E1CP-D110	For KOREA 17mm ICE,220V,60Hz of IM-240AWNE
IM-240AWNE	E1CP-D120	For KOREA, 220V,60Hz of IM-240AWNE
IM-240AWNE-23	E1CP-D121	For KOREA 23mm ICE,220V,60Hz of IM-240AWNE
IM-240AWNE-21	E1CP-D122	For KOREA 21mm ICE,220V,60Hz of IM-240AWNE
IM-240ANE(HS)	E1CP-D123	For Singapore special water valve
IM-240ANE-23(HS)	E1CP-D124	23mm ICE for Singapore special water valve
IM-240ANE-21(HS)	E1CP-D125	21mm ICE for Singapore special water valve
IM-240ANE(KR)	E1CP-D126	For KOREA,220V,60Hz
IM-240ANE-SN	E1CP-D200	Ti Evaporator

AUXILIARY CODE

U - 1

The auxiliary code is the first two characters in the serial number. The first character indicates the production year. Years progress or regress in alphabetical order. The series of letters and skipped letters depend on UL listing, production, and model. See the auxiliary code(s) and corresponding year(s) on the front cover.

The second character indicates significant part changes within the same year. Base is "1" and this number advances for each change. If there is no significant part change at the turn of the year, this number starts from "0."

MARKS LOCATED UNDER THE AUXILIARY CODE

- = Part deleted.
- x = Part deleted and replaced by "o" part.
- o = New part in place of "x" part.

FASTENER PART NUMBER

SCREWS

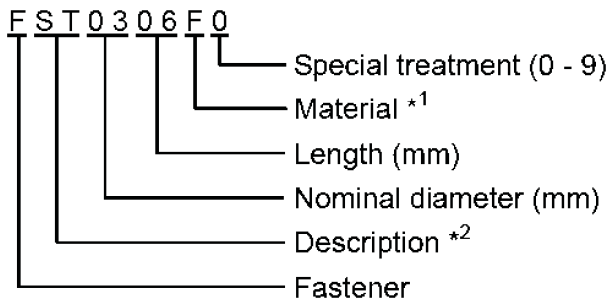

^{*1} Material

- F: Steel
- S: Austenitic stainless steel
- M: Martensitic stainless steel
- B: Copper alloy
- P: Polycarbonate
- N: Polyamide
- V: PVC
- A: ABS
- X: Polyacetal
- L: Aluminum

NUTS & WASHERS

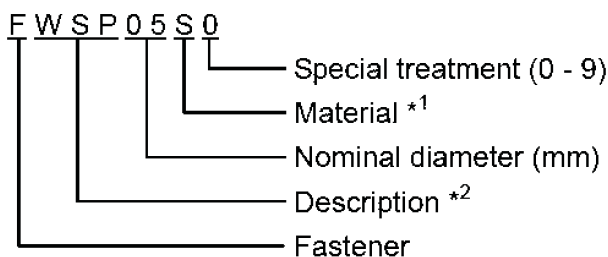

^{*2} Description

- First letter
- S: Machine screw
- T: Tapping screw
- M: Wood screw
- B: Bolt
- W: Washer
- N: Nut

IM-240ANE (-23)
IM-240AWNE (-21, -23, -23)

50Hz (A-1) to (B-0)
60Hz (A-1) to (C-0)

A. ICE CUBBER ASSY (1/2)

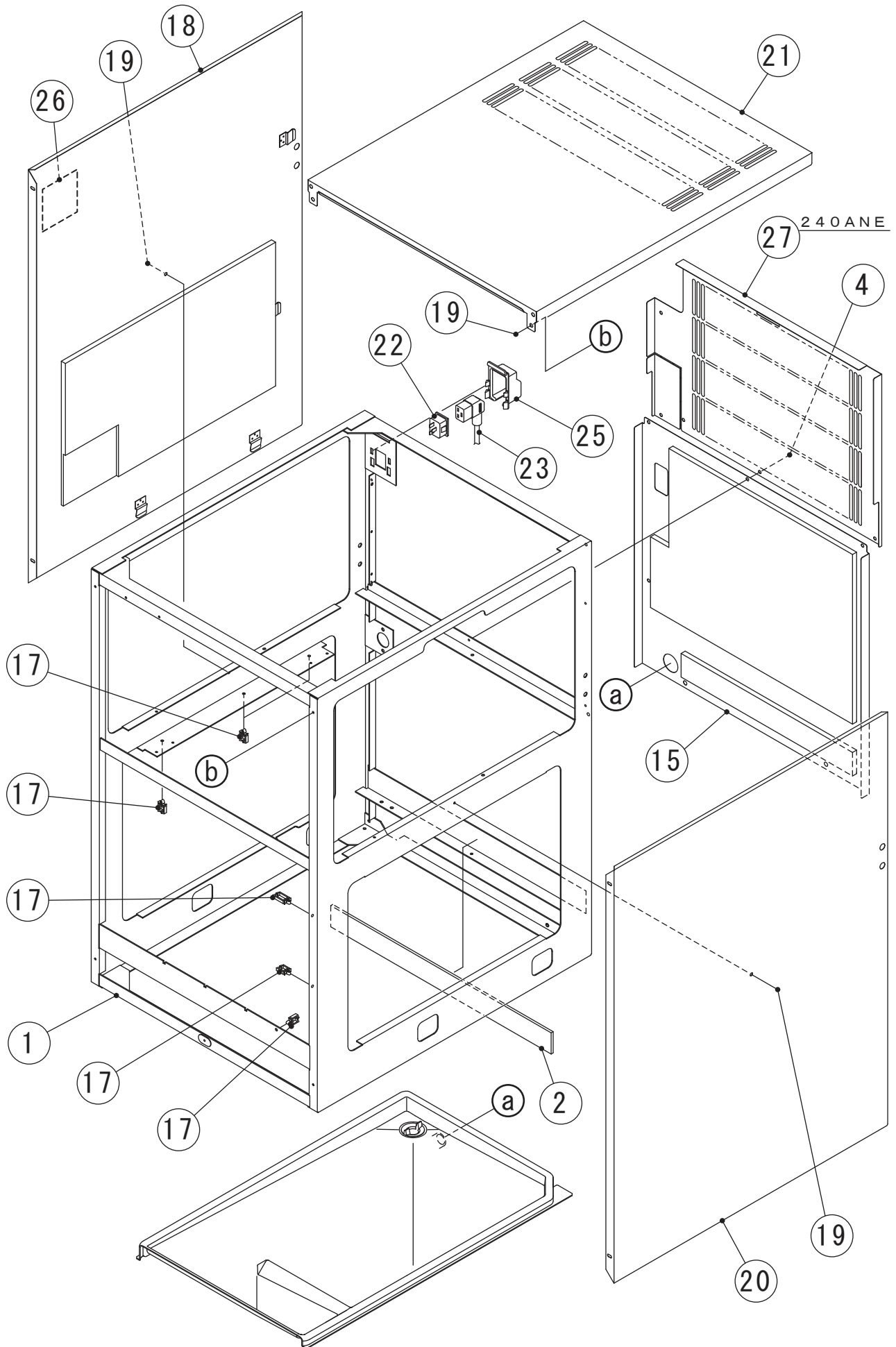

IM-240ANE (-23)
IM-240AWNE (-21, -23, -17)

50Hz (A-1) to (B-0)
60Hz (A-1) to (C-0)

A. ICE CUBBER ASSY (2/2)

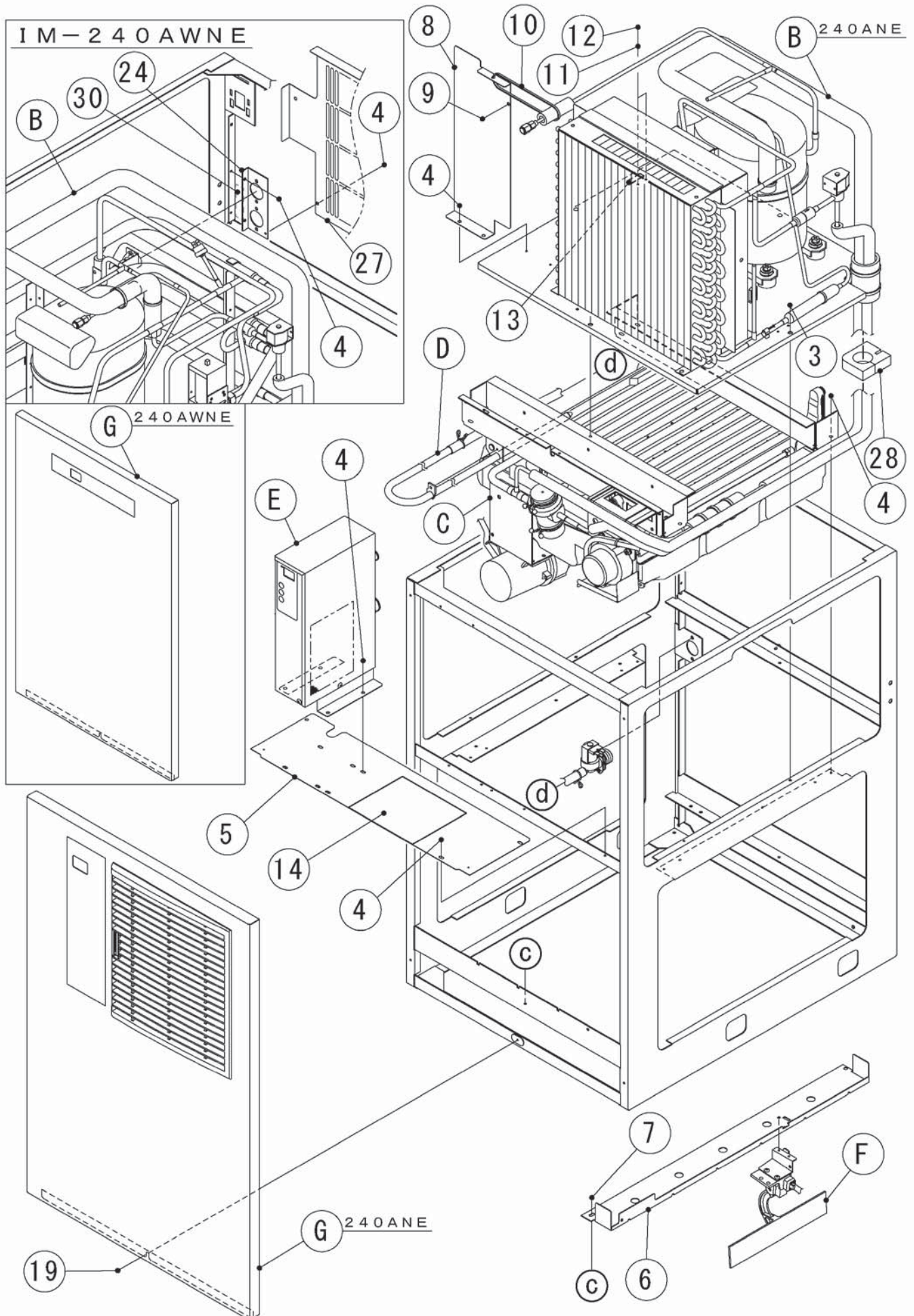

IM-240ANE (-21,-23)
IM-240AWNE(-21,-23,-17)

A. ICE CUBBER ASSY (1/2)

50Hz (B-1) and later
60Hz (C-1) and later

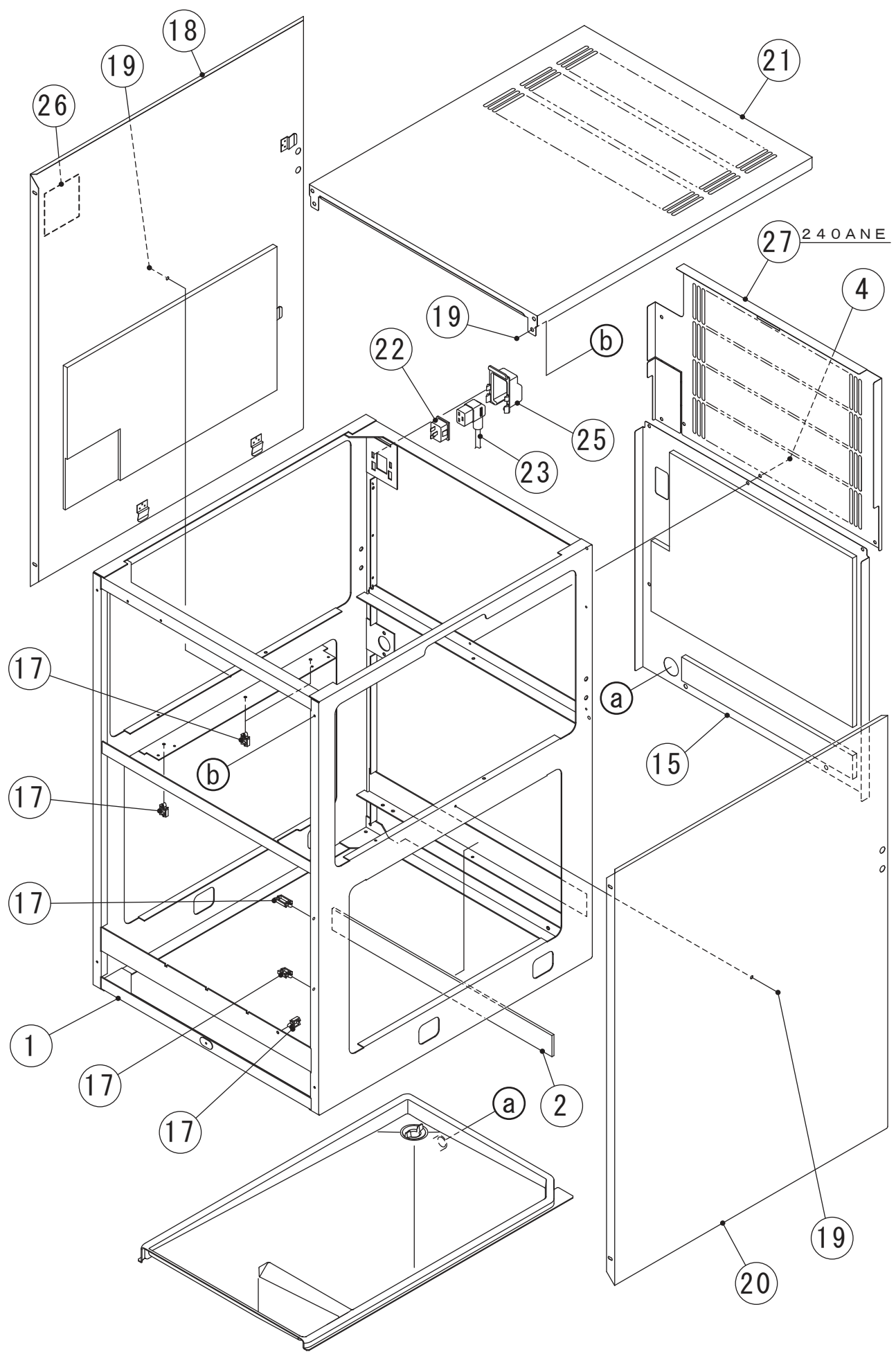

IM-240ANE (-21,-23)
IM-240AWNE(-21,-23,-17)

A. ICE CUBBER ASSY (2/2)

50Hz (B-1) and later
60Hz (C-1) and later

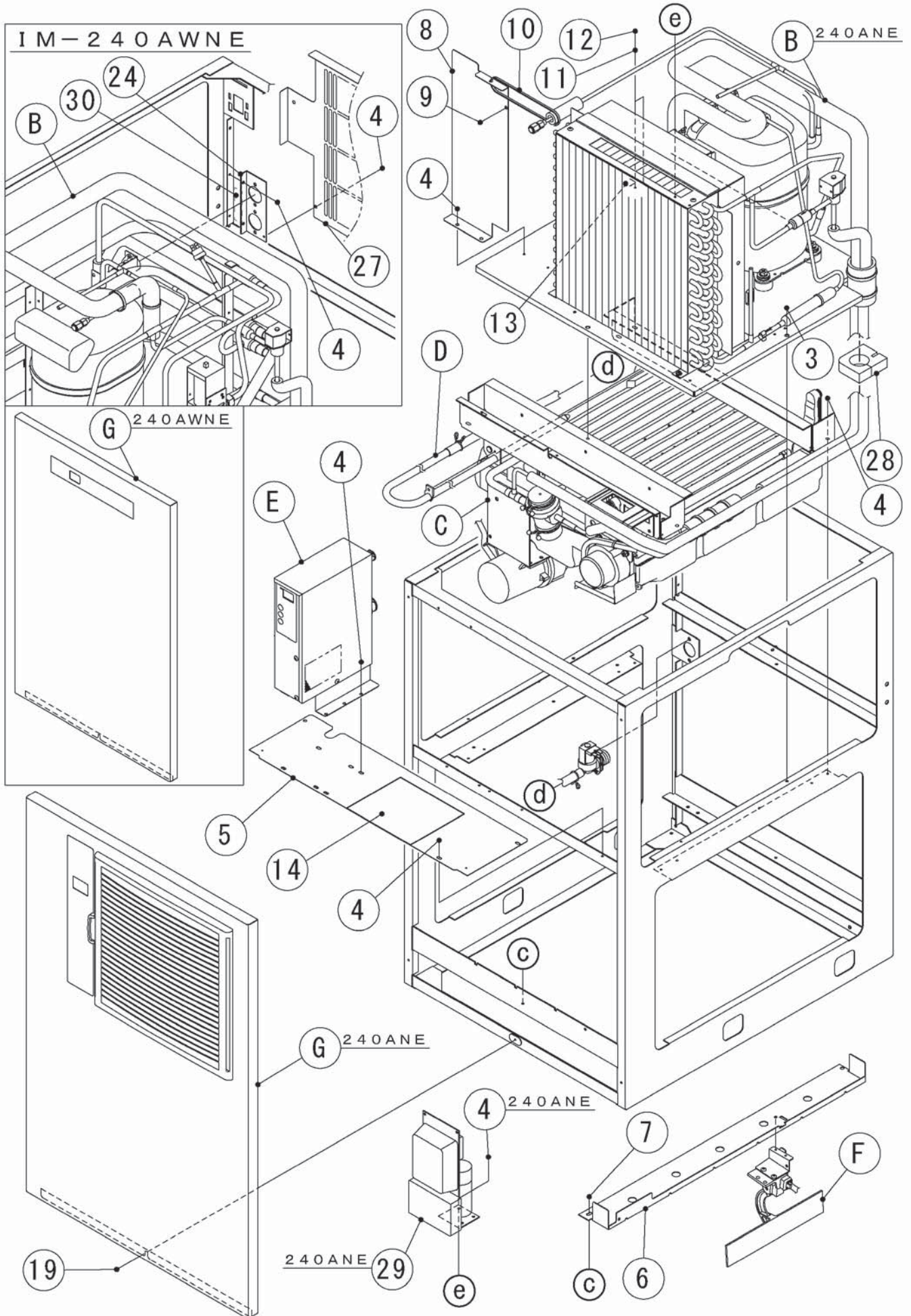

MODEL: IM-240ANE,-21,-23 IM-240AWNE,-21,-23,-17				TITLE: A.ICE CUBBER ASSY				
INDEX NO.	DESCRIPTION	MATERIAL OR MODEL NUMBER	PART NUMBER	REQ'D NUMBER				
				A-1 B-0	B-1 B-2	B-3 C-0	C-1 G-0	G-1
B	REFRIGERATION ASSY	(240ANE,-21,-23) (50Hz)	1H4741A01	1	-	-	-	-
		(240ANE)(60Hz)	1H5195A01	-	1	1	1	1
				-	-	-	1	1
		(240AWNE,-21,-23) (50Hz)	1H4792A01	1	-	-	-	-
			1H5206A01	-	1	1	1	1
		(240AWNE,-21,-23,-17) (60Hz)	1H4792A01	1	1	1	-	-
1H5206A01	-		-	-	1	1		
C	MECHANISM ASSY		1H4743A01	1	1	1	1	1
D	WATER CIRCUIT ASSY		2X0229A01	1	1	1	1	1
E	CONTROL BOX ASSY	(240ANE,-21,-23)	2X0231A01	1	-	-	-	-
			2X1197A01	-	1	1	1	1
		(240AWNE,-21,-23) (50Hz)	2X0353A01	1	-	-	-	-
			2X1197A02	-	1	1	1	1
(240AWNE,-21,-23,-17) (60Hz)	2X0353A01	1	1	1	-	-		
	2X1197A02	-	-	-	1	1		
F	BIN SWITCH - 2 ASSY		3Y5468A01	1	1	1	1	1
G	FRONT COVER ASSY	(240ANE,-21,-23)	2X0240A01	1	-	-	-	-
			2X1201A01	-	1	1	1	1
		(240AWNE,-21,-23) (50Hz)	2X0358A01	1	-	-	-	-
			2X1241A01	-	1	1	1	1
		(240AWNE,-21,-23,-17) (60Hz)	2X0358A01	1	1	1	-	-
2X1241A01	-		-	-	1	1		
K	ACCESSORIES		A02335-01	1	1	1	1	1
L	OPTIONAL PARTS		OPT-E1CP	1	1	1	1	1
1	UNIT FRAME		1H4740G01	1	1	1	1	1
		(SUS316)	1H5537G01	-	-	-	1	1
2	INSULATION - FRAME (A)		4Y6982P01	1	1	1	1	1
3	HEX HEAD BOLT (SPRING WASHER AND FLAT WASHER)		FBK0620S0	4	4	4	4	4
4	FLANGE BOLT (C-TITE)	(240ANE,-21,-23)	FTR0408M0	24	24	24	24	24
		(240AWNE,-21,-23)(50Hz)		25	27	27	27	27
		(240AWNE,-21,-23,-17)(60Hz)		25	25	25	27	27
5	COVER - FRAME	(50Hz)	4Y6913G01	1	-	-	-	-
			4Y7825G01	-	1	1	1	1
		(60Hz)	4Y6913G01	1	1	1	-	-
			4Y7825G01	-	-	-	1	1
6	FRAME - BIN SWITCH		3Y5348M01	1	1	1	1	1

MODEL: IM-240ANE,-21,-23 IM-240AWNE,-21,-23,-17			TITLE: A.ICE CUBBER ASSY					
INDEX NO.	DESCRIPTION	MATERIAL OR MODEL NUMBER	PART NUMBER	REQ'D NUMBER				
				A-1 B-0	B-1 B-2	B-3 C-0	C-1 G-0	G-1
7	HEX HEAD BOLT (SPRING WASHER AND FLAT WASHER)		FBK0510S0	2	2	2	2	2
8	PLATE - UNIT	(240ANE,-21,-23)	3Y5381M01	1	1	1	1	1
		(240ANE)(60Hz)	3Y7371M01	-	-	-	1	1
9	TRUSS HEAD TAPPING SCREW T2	(240ANE,-21,-23)	FT20408F0	1	1	1	1	1
10	TIE	(240ANE,-21,-23)	7920-0003	1	1	1	1	1
11	SPRING WASHER		FWSP04S0	2	2	2	2	2
12	TRUSS HEAD MACHINE SCREW		FST0408S0	2	2	2	2	2
13	LABEL - GROUND	(50Hz)	451712-01	1	-	-	-	-
	LABEL - GROUND (B)		450452-02	-	1	1	1	1
	LABEL - GROUND	(60Hz)	451712-01	1	1	1	-	-
	LABEL - GROUND (B)		450452-02	-	-	-	1	1
14	WIRING LABEL	(50Hz)	3Y5103L01	1	-	-	-	-
			3Y6692L01	-	1	1	1	1
		(60Hz)	3Y5103L01	1	1	1	-	-
			3Y6692L01	-	-	-	1	1
15	REAR PANEL		3Y5785G01	1	1	1	1	1
17	WIRE SADDLE		428060-02	6	6	6	6	6
18	SIDE PANEL (L)		3Y5419G01	1	1	1	1	1
19	TRUSS HEAD TAPPING SCREW (S-TITE)		FTS0408M0	15	15	15	15	15
20	SIDE PANEL (R)		2X0281G01	1	1	1	1	1
21	TOP PANEL		2X0236M01	1	1	1	1	1
22	CONNECTOR		P00246-01	1	1	1	1	1
23	POWER SUPPLY CORD	EU-PLUG(16A)	P03362-01	1	1	1	1	1
		UK-PLUG(13A)	P03363-01	1	1	1	1	1
		AS-PLUG(15A)	P03364-01	1	1	1	1	1
		KOREA-PLUG (ORDER HKR)	P04438-01	1	1	1	1	1
24	BRACKET - FITTING	(240AWNE,-21,-23,-17)	4Y3072-01	1	1	1	1	1
25	COVER - CONNECTOR	(EXCEPT for KOREA)	2X0271P01	1	1	1	1	1
26	NAME PLATE		N/A	1	1	1	1	1
27	REAR PANEL UP	(240ANE,-21,-23)	2X0612M01	1	1	1	1	1
		(240AWNE,-21,-23,-17)	2X0613M01	1	1	1	1	1
28	INSULATION		4Y0306-01	1	1	1	1	1
29	STARTING DEVICE	(50Hz)	P01856-01	-	1	1	1	1
		(60Hz)	P02887-01	-	-	-	1	1
30	LABEL-CONNECTION	(240AWNE,-21,-23,-17)	464541-01	1	1	1	1	1

MODEL: IM-240ANE,-21,-23 IM-240AWNE,-21,-23,-17			TITLE: A.ICE CUBBER ASSY					
INDEX NO.	DESCRIPTION	MATERIAL OR MODEL NUMBER	PART NUMBER	REQ'D NUMBER				
				G-2 J-0	J-1	J-2 K-0	K-1	K-2
1	UNIT FRAME		1H4740G01	1	1	1	1	-
		(SUS316)	1H5537G01	1	1	1	1	-
			1E0033G01	-	-	-	-	1
2	INSULATION - FRAME (A)		4Y6982P01	1	1	1	1	1
3	HEX HEAD BOLT		FBK0620S0	4	4	4	4	4
	(SPRING WASHER AND FLAT WASHER)							
4	FLANGE BOLT (C-TITE)	(240ANE,-21,-23)	FTR0408M0	24	24	24	24	26
		(240AWNE,-21,-23)(50Hz)		27	27	27	27	27
		(240AWNE,-21,-23,-17)(60Hz)		27	27	27	27	27
5	COVER - FRAME		4Y7825G01	1	1	1	1	1
6	FRAME - BIN SWITCH		3Y5348M01	1	1	1	1	-
			3E0009M01	-	-	-	-	1
7	HEX HEAD BOLT		FBK0510S0	2	2	2	2	2
	(SPRING WASHER AND FLAT WASHER)							
8	PLATE - UNIT	(240ANE,-21,-23)	3Y5381M01	1	1	1	1	1
		(240ANE)(60Hz)	3Y7371M01	1	1	1	1	1
9	TRUSS HEAD TAPPING SCREW T2	(240ANE,-21,-23)	FT20408F0	1	1	1	1	1
10	TIE	(240ANE,-21,-23)	7920-0003	1	1	1	1	1
11	SPRING WASHER		FWSP04S0	2	2	2	2	2
12	TRUSS HEAD MACHINE SCREW		FST0408S0	2	2	2	2	2
13	LABEL - GROUND (B)		450452-02	1	1	1	1	-
14	WIRING LABEL		3Y6692L01	1	1	1	1	1
15	REAR PANEL		3Y5785G01	1	1	1	1	1
17	WIRE SADDLE		428060-02	6	6	6	6	6
18	SIDE PANEL (L)		3Y5419G01	1	1	1	1	1
19	TRUSS HEAD TAPPING SCREW (S-TITE)		FTS0408M0	15	15	15	15	15
20	SIDE PANEL (R)		2X0281G01	1	1	1	1	1
21	TOP PANEL		2X0236M01	1	1	1	1	1
22	CONNECTOR		P00246-01	1	1	1	1	1
23	POWER SUPPLY CORD	EU-PLUG(16A)	P03362-01	1	1	1	1	1
		UK-PLUG(13A)	P03363-01	1	1	1	1	1
		AS-PLUG(15A)	P03364-01	1	1	1	1	1
		KOREA-PLUG (ORDER HKR)	P04438-01	1	1	1	1	1
24	BRACKET - FITTING	(240AWNE,-21,-23,-17)	4Y3072-01	1	1	1	1	1
25	COVER - CONNECTOR	(EXCEPT for KOREA)	2X0271P01	1	1	1	1	1
26	NAME PLATE		N/A	-	-	-	-	-

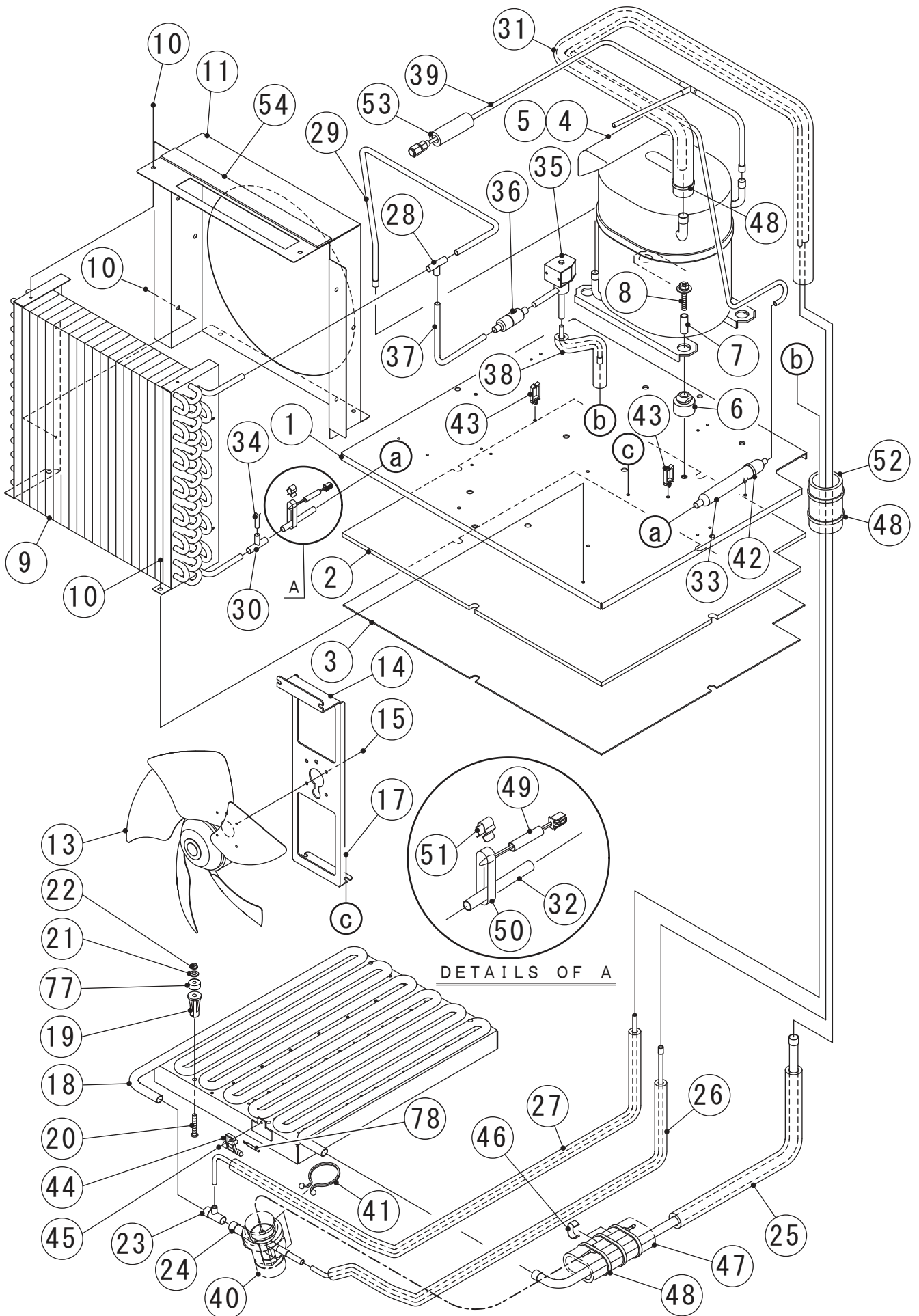

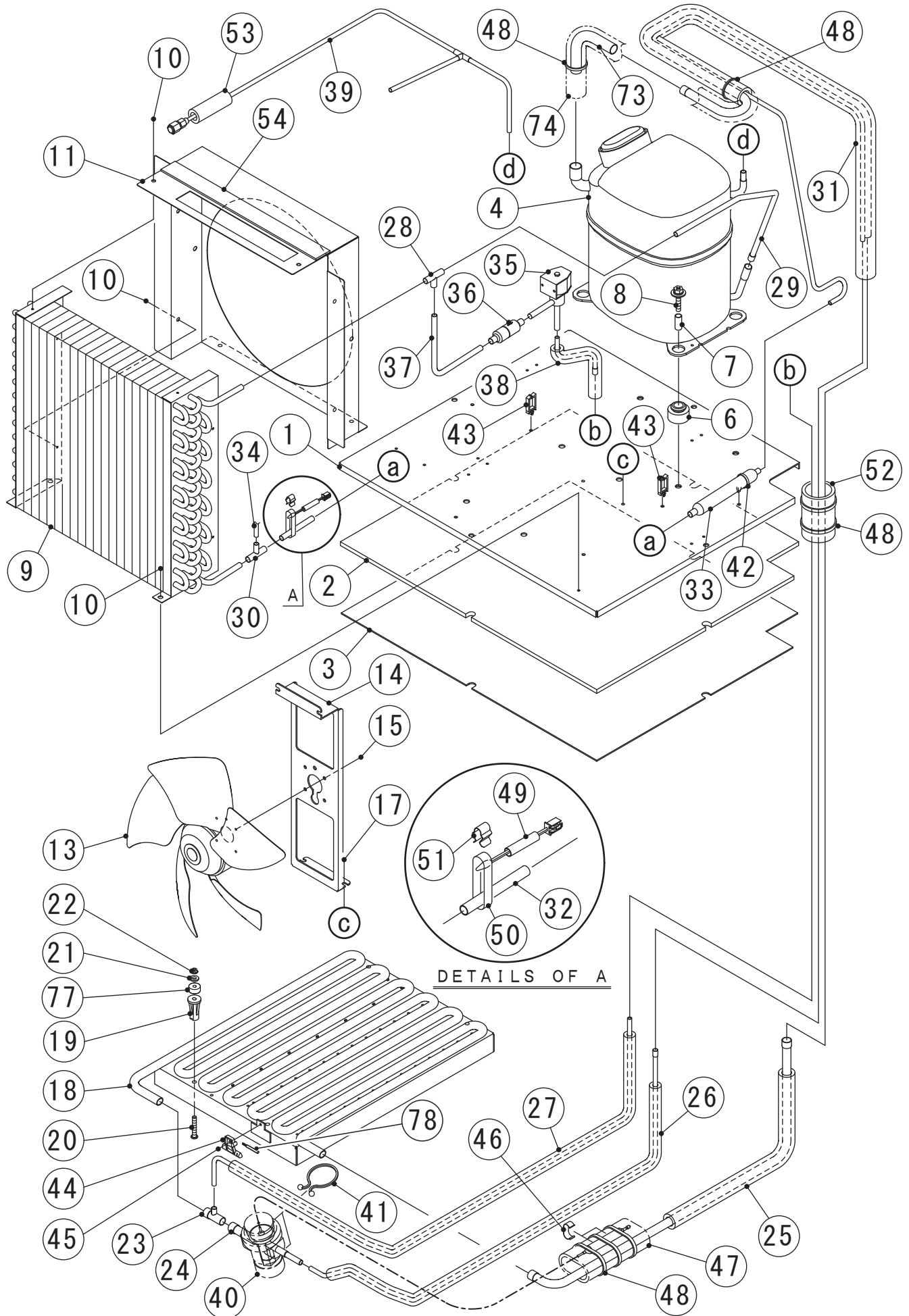

MODEL: IM-240ANE,-21,-23

TITLE: B.REFRIGERATION ASSY

【50Hz】

INDEX NO.	DESCRIPTION	MATERIAL OR MODEL NUMBER	PART NUMBER	REQ'D NUMBER				
				A-1 B-0	B-1 B-2	B-3 C-0	C-1 G-0	G-1
1	BASE		3Y5351G01	1	1	1	1	1
2	INSULATION - BASE		4Y6898P01	1	1	1	1	1
3	PLATE - BASE		4Y0249-01	1	1	1	1	1
4	COMPRESSOR		4A1581-01	1	-	-	-	-
			P01855-01	-	1	1	1	1
5	MOTOR PROTECTOR		4A1581F01	1	-	-	-	-
6	GROMMET		434922-02	4	-	-	-	-
	RUBBER GROMMET		P01858-01	-	4	4	4	4
7	SPACER		434921-01	4	-	-	-	-
	SLEEVE		P01859-01	-	4	4	4	4
8	BOLT		436206-04	4	-	-	-	-
			436206-03	-	4	4	4	4
9	CONDENSER		P03307-01	1	1	1	1	1
10	FLANGE BOLT (C-TITE)		FTR0408M0	8	8	8	8	8
11	SHROUD		2H9947M01	1	1	1	1	1
13	FAN MOTOR		P02545-01	1	1	1	1	1
14	BRACKET - FM		3Y5075M01	1	1	1	1	1
15	HEX HEAD BOLT (SPRING WASHER AND FLAT WASHER)		FBK0408F0	5	5	5	5	5
17	HEX HEAD BOLT (SPRING WASHER AND FLAT WASHER)		FBK0510S0	4	4	4	4	4
18	EVAPORATOR	(240ANE)	2H7526G02	1	1	1	1	1
		(240ANE-23)	2H1833G03	1	1	1	1	1
		(240ANE-21)	208205G04	1	1	1	1	1
19	COLLAR		3H3879-01	4	4	4	4	4
20	SCREW EVAPORATOR	(240ANE)	4Y4922M02	4	4	4	4	4
		(240ANE-21)	4Y4922M03	4	4	4	4	4
		(240ANE-23)						
21	WASHER		4H0777-01	4	4	4	4	4
22	FLANGE NUT		FNHF06S0	4	4	4	4	4
23	TEE		430608-02	1	1	1	1	1
24	EXPANSION VALVE		P01874-01	1	1	1	1	1
25	COPPER TUBE (A) - LOW SIDE		3Y5353G01	1	1	1	1	1
26	COPPER TUBE (E) - HIGH SIDE		3Y5354G01	1	1	1	1	1
27	COPPER TUBE (D) - HOT GAS		3Y5355G01	1	1	1	1	1
28	TEE		420041-11	1	1	1	1	1

MODEL: IM-240ANE,-21,-23

TITLE: B.REFRIGERATION ASSY

【50Hz】

INDEX NO.	DESCRIPTION	MATERIAL OR MODEL NUMBER	PART NUMBER	REQ'D NUMBER				
				G-2 J-0	J-1	J-2 K-0	K-1	K-2 L-2
1	BASE		3Y5351G01	1	1	1	1	1
2	INSULATION - BASE		4Y6898P01	1	1	1	1	1
3	PLATE - BASE		4Y0249-01	1	1	1	1	1
4	COMPRESSOR		P01855-01	1	1	1	1	1
6	RUBBER GROMMET		P01858-01	4	4	4	4	4
7	SLEEVE		P01859-01	4	4	4	4	4
8	BOLT		436206-03	4	4	4	4	4
9	CONDENSER		P03307-01	1	1	1	1	1
10	FLANGE BOLT (C-TITE)		FTR0408M0	8	8	8	8	8
11	SHROUD		2H9947M01	1	1	1	1	1
13	FAN MOTOR		P02545-01	1	1	1	1	1
14	BRACKET - FM		3Y5075M01	1	1	1	1	1
15	HEX HEAD BOLT (SPRING WASHER AND FLAT WASHER)		FBK0408F0	5	5	5	5	5
17	HEX HEAD BOLT (SPRING WASHER AND FLAT WASHER)		FBK0510S0	4	4	4	4	4
18	EVAPORATOR	(240ANE)	2H7526G02	-	-	-	-	-
			2X2459G01	1	1	1	1	1
		(240ANE for KOREA)	2H7526G02	-	-	-	-	-
			2E0046G01	1	1	1	1	1
		(240ANE-23)	2H1833G03	1	1	-	-	-
			2X2594G01	-	-	1	1	1
		(240ANE-23 for KOREA)	2H1833G03	1	1	-	-	-
			2E0049G01	-	-	1	1	1
		(240ANE-21)	208205G04	1	1	1	-	-
			2X2532G01	-	-	-	1	1
(240ANE-21 for KOREA)	208205G04	1	1	1	-	-		
	2E0051G01	-	-	-	1	1		
19	COLLAR		3H3879-01	4	4	4	4	4
20	SCREW EVAPORATOR	(240ANE)	4Y4922M02	4	4	4	4	4
		(240ANE-21) (240ANE-23)	4Y4922M03	4	4	4	4	4
21	WASHER		4H0777-01	4	4	4	4	4
22	FLANGE NUT		FNHF06S0	4	4	4	4	4
23	TEE		430608-02	1	1	1	1	1
24	EXPANSION VALVE		P01874-01	1	1	1	1	1
25	COPPER TUBE (A) - LOW SIDE		3Y5353G01	1	1	1	1	1
26	COPPER TUBE (E) - HIGH SIDE		3Y5354G01	1	1	1	1	1
27	COPPER TUBE (D) - HOT GAS		3Y5355G01	1	1	1	1	1
28	TEE		420041-11	1	1	1	1	1

MODEL: IM-240ANE,-21,-23

TITLE: B.REFRIGERATION ASSY

【50Hz】

INDEX NO.	DESCRIPTION	MATERIAL OR MODEL NUMBER	PART NUMBER	REQ'D NUMBER				
				L-3				
1	BASE		3Y5351G01	1				
2	INSULATION - BASE		4Y6898P01	1				
3	PLATE - BASE		4Y0249-01	1				
4	COMPRESSOR		P01855-01	1				
6	RUBBER GROMMET		P01858-01	4				
7	SLEEVE		P01859-01	4				
8	BOLT		436206-03	4				
9	CONDENSER		P03307-01	1				
10	FLANGE BOLT (C-TITE)		FTR0408M0	8				
11	SHROUD		2H9947M01	1				
13	FAN MOTOR		P02545-01	1				
14	BRACKET - FM		3Y5075M01	1				
15	HEX HEAD BOLT (SPRING WASHER AND FLAT WASHER)		FBK0408F0	5				
17	HEX HEAD BOLT (SPRING WASHER AND FLAT WASHER)		FBK0510S0	4				
18	EVAPORATOR	(240ANE)	2H7526G02	-				
			2X2459G01	1				
		(240ANE-SN)	2E0046G01	1				
			(240ANE for KOREA)	2H7526G02	-			
		2E0046G01		1				
		(240ANE-23)	2H1833G03	-				
			2X2594G01	1				
		(240ANE-23 for KOREA)	2H1833G03	-				
			2E0049G01	1				
		(240ANE-21)	208205G04	-				
2X2532G01	1							
(240ANE-21 for KOREA)	208205G04	-						
	2E0051G01	1						
19	COLLAR		3H3879-01	4				
20	SCREW EVAPORATOR	(240ANE)	4Y4922M02	4				
		(240ANE-21) (240ANE-23)	4Y4922M03	4				
21	WASHER		4H0777-01	4				
22	FLANGE NUT		FNHF06S0	4				
23	TEE		430608-02	1				
24	EXPANSION VALVE		P01874-01	1				
25	COPPER TUBE (A) - LOW SIDE		3Y5353G01	1				
26	COPPER TUBE (E) - HIGH SIDE		3Y5354G01	1				

MODEL: IM-240ANE

TITLE: B.REFRIGERATION ASSY

【60Hz】

INDEX NO.	DESCRIPTION	MATERIAL OR MODEL NUMBER	PART NUMBER	REQ'D NUMBER				
				C-1 G-0	G-1	G-2 J-0	J-1	J-2 K-0
1	BASE		3Y5351G01	1	1	1	1	1
2	INSULATION - BASE		4Y6898P01	1	1	1	1	1
3	PLATE - BASE		4Y0249-01	1	1	1	1	1
4	COMPRESSOR		P02886-01	1	1	1	1	1
6	RUBBER GROMMET		P01858-01	4	4	4	4	4
7	SLEEVE		P01859-01	4	4	4	4	4
8	BOLT		436206-03	4	4	4	4	4
9	CONDENSER		P03307-01	1	1	1	1	1
10	FLANGE BOLT (C-TITE)		FTR0408M0	8	8	8	8	8
11	SHROUD		2H9947M01	1	1	1	1	1
13	FAN MOTOR		P02545-01	1	1	1	1	1
14	BRACKET - FM		3Y5075M01	1	1	1	1	1
15	HEX HEAD BOLT (SPRING WASHER AND FLAT WASHER)		FBK0408F0	5	5	5	5	5
17	HEX HEAD BOLT (SPRING WASHER AND FLAT WASHER)		FBK0510S0	4	4	4	4	4
18	EVAPORATOR		2H7526G02	1	1	-	-	-
			2X2459G01	-	-	1	1	1
		(240ANE for KOREA)	2H7526G02	1	1	-	-	-
			2E0046G01	-	-	1	1	1
19	COLLAR		3H3879-01	4	4	4	4	4
20	SCREW EVAPORATOR		4Y4922M02	4	4	4	4	4
21	WASHER		4H0777-01	4	4	4	4	4
22	FLANGE NUT		FNHF06S0	4	4	4	4	4
23	TEE		430608-02	1	1	1	1	1
24	EXPANSION VALVE		P01874-01	1	1	1	1	1
25	COPPER TUBE (A) - LOW SIDE		3Y5353G01	1	1	1	1	1
26	COPPER TUBE (E) - HIGH SIDE		3Y5354G01	1	1	1	1	1
27	COPPER TUBE (D) - HOT GAS		3Y5355G01	1	1	1	1	1
28	TEE		420041-11	1	1	1	1	1
29	PIPE(A) - HIGH SIDE		4Y7816M01	1	1	1	1	1
30	TEE		420041-02	1	1	1	1	1
31	HEAT EXCHANGER		3Y3207G01	1	1	1	1	1
32	PIPE(F) - HIGH SIDE		4Y6750M01	1	1	1	1	1
33	DRIER		458776-01	1	1	1	1	1
34	PROCESS TUBE		4Y0273-01	1	1	1	1	1
35	HOT GAS VALVE		P04242-01	1	1	1	1	1
		ONLY KOREA	P01871-01	1	1	1	1	1
36	STRAINER		P00812-01	1	1	1	1	1

MODEL: IM-240ANE

TITLE: B.REFRIGERATION ASSY

【60Hz】

INDEX NO.	DESCRIPTION	MATERIAL OR MODEL NUMBER	PART NUMBER	REQ'D NUMBER				
				K-1	K-2			
1	BASE		3Y5351G01	1	1			
2	INSULATION - BASE		4Y6898P01	1	1			
3	PLATE - BASE		4Y0249-01	1	1			
4	COMPRESSOR		P02886-01	1	1			
6	RUBBER GROMMET		P01858-01	4	4			
7	SLEEVE		P01859-01	4	4			
8	BOLT		436206-03	4	4			
9	CONDENSER		P03307-01	1	1			
10	FLANGE BOLT (C-TITE)		FTR0408M0	8	8			
11	SHROUD		2H9947M01	1	1			
13	FAN MOTOR		P02545-01	1	1			
14	BRACKET - FM		3Y5075M01	1	1			
15	HEX HEAD BOLT (SPRING WASHER AND FLAT WASHER)		FBK0408F0	5	5			
17	HEX HEAD BOLT (SPRING WASHER AND FLAT WASHER)		FBK0510S0	4	4			
18	EVAPORATOR		2X2459G01	1	1			
		(240ANE for KOREA)	2E0046G01	1	1			
19	COLLAR		3H3879-01	4	4			
20	SCREW EVAPORATOR		4Y4922M02	4	4			
21	WASHER		4H0777-01	4	4			
22	FLANGE NUT		FNHF06S0	4	4			
23	TEE		430608-02	1	1			
24	EXPANSION VALVE		P01874-01	1	1			
25	COPPER TUBE (A) - LOW SIDE		3Y5353G01	1	1			
26	COPPER TUBE (E) - HIGH SIDE		3Y5354G01	1	1			
27	COPPER TUBE (D) - HOT GAS		3Y5355G01	1	1			
28	TEE		420041-11	1	1			
29	PIPE(A) - HIGH SIDE		4Y7816M01	1	1			
30	TEE		420041-02	1	1			
31	HEAT EXCHANGER		3Y3207G01	1	1			
32	PIPE(F) - HIGH SIDE		4Y6750M01	1	1			
33	DRIER		458776-01	1	1			
34	PROCESS TUBE		4Y0273-01	1	1			
35	HOT GAS VALVE		P04242-01	1	1			
		ONLY KOREA	P01871-01	1	1			
36	STRAINER		P00812-01	1	1			
37	PIPE(A) - HOT GAS		4Y6895M01	1	1			
38	PIPE(B) - HOT GAS		4Y7012G01	1	1			

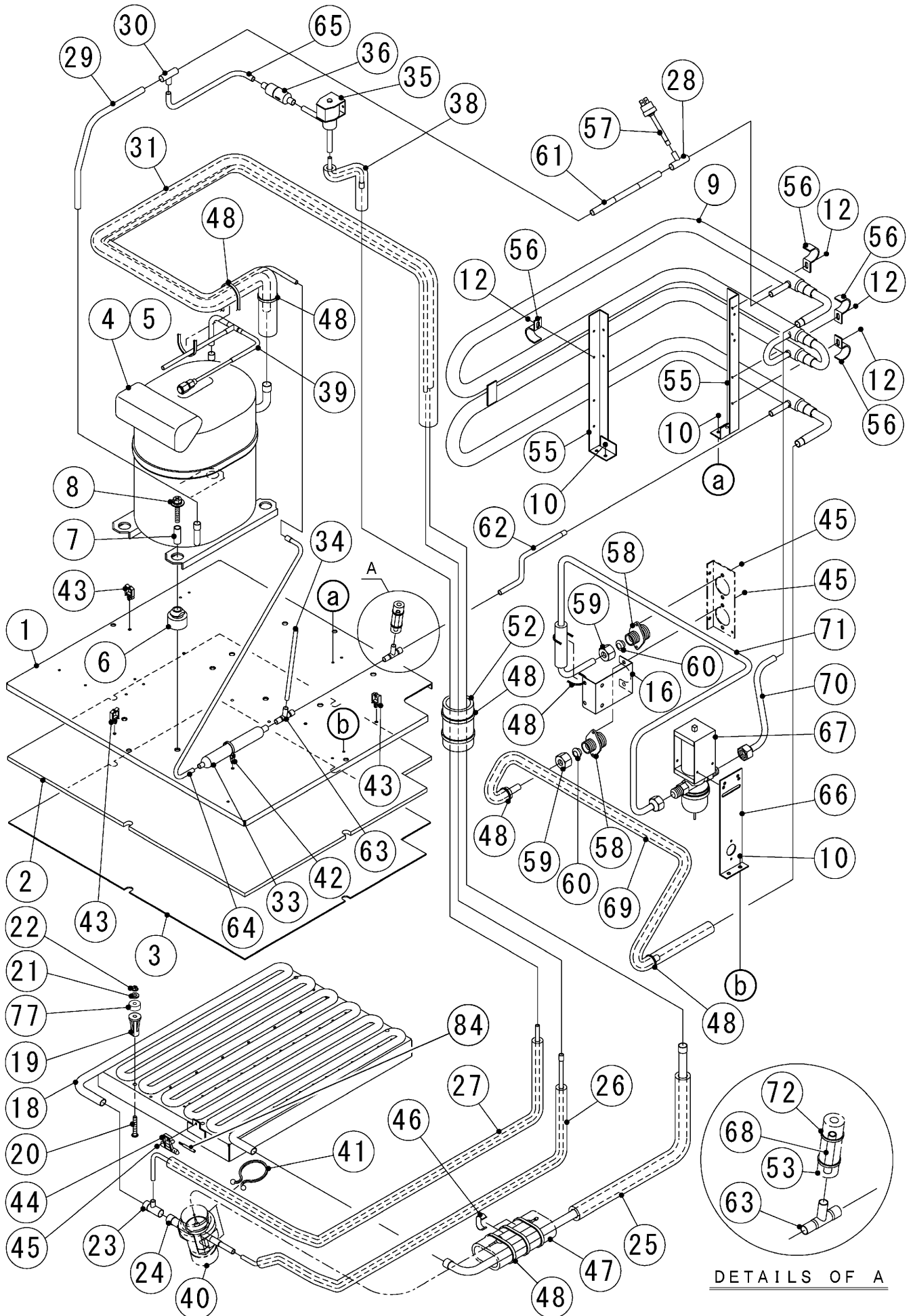

B. REFRIGERATION ASSY

50Hz (B-1) and later
60Hz (C-1) and later

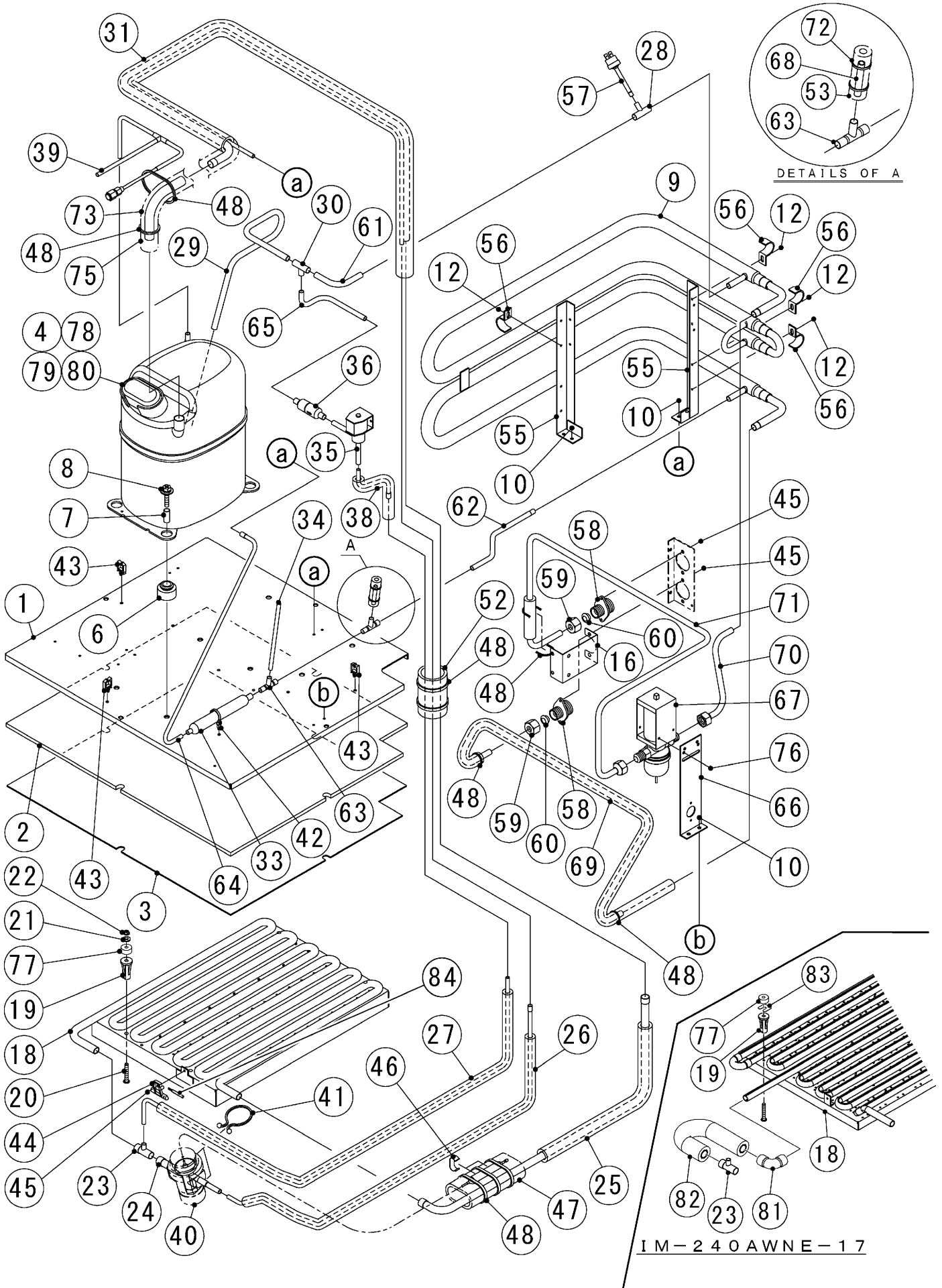

MODEL:		TITLE: B.REFRIGERATION ASSY						
IM-240AWNE,-23		【50Hz】						
INDEX NO.	DESCRIPTION	MATERIAL OR MODEL NUMBER	PART NUMBER	REQ'D NUMBER				
				A-1 B-0	B-1 B-2	B-3 C-0	C-1 G-0	G-1
1	BASE		3Y5530G01	1	1	1	1	1
2	INSULATION - BASE		4Y6898P01	1	1	1	1	1
3	PLATE - BASE		4Y0249-01	1	1	1	1	1
4	COMPRESSOR		4A1581-01	1	-	-	-	-
			P01855-01	-	1	1	1	1
5	MOTOR PROTECTOR		4A1581F01	1	-	-	-	-
6	GROMMET		434922-02	4	-	-	-	-
	RUBBER GROMMET		P01858-01	-	4	4	4	4
7	SPACER		434921-01	4	-	-	-	-
	SLEEVE		P01859-01	-	4	4	4	4
8	BOLT		436206-04	4	-	-	-	-
			436206-03	-	4	4	4	4
9	CONDENSER - WATER COOLED		103099G01	1	1	1	1	1
10	FLANGE BOLT (C-TITE)		FTR0408M0	6	6	6	6	6
12	TRUSS HEAD TAPPING SCREW T2		FT20408F0	4	4	4	4	4
16	BRACKET - WATER PIPE		4Y7086M01	1	1	1	1	1
18	EVAPORATOR	(240AWNE)	2H7526G02	1	1	1	1	1
		(240AWNE-23)	2H1833G03	1	1	1	1	1
19	COLLAR		3H3879-01	4	4	4	4	4
20	SCREW EVAPORATOR	(240AWNE)	4Y4922M02	4	4	4	4	4
		(240AWNE-23)	4Y4922M03	4	4	4	4	4
21	WASHER		4H0777-01	4	4	4	4	4
22	FLANGE NUT		FNHF06S0	4	4	4	4	4
23	TEE		430608-02	1	1	1	1	1
24	EXPANSION VALVE		P01874-01	1	1	1	1	1
25	COPPER TUBE (A) - LOW SIDE		3Y5353G01	1	1	1	1	1
26	COPPER TUBE (E) - HIGH SIDE		3Y5354G01	1	1	1	1	1
27	COPPER TUBE (D) - HOT GAS		3Y5355G01	1	1	1	1	1
28	TEE		420041-05	1	1	1	1	1
29	PIPE(A-1) - HIGH SIDE		3Y5531M01	1	-	-	-	-
			4Y7836M01	-	1	1	1	1
30	TEE		420041-09	1	1	1	1	1
31	HEAT EXCHANGER		2X0352G01	1	-	-	-	-
			2X1238G01	-	1	1	1	1
33	DRIER		458776-01	1	1	1	1	1
34	PROCESS TUBE		4Y0273-01	1	1	1	1	1
35	HOT GAS VALVE		P04242-01	1	1	1	1	1
36	STRAINER		P00812-01	1	1	1	1	1
38	PIPE(B) - HOT GAS		4Y7012G01	1	1	1	1	1

MODEL: IM-240AWNE,-23		TITLE: B.REFRIGERATION ASSY 【50Hz】						
INDEX NO.	DESCRIPTION	MATERIAL OR MODEL NUMBER	PART NUMBER	REQ'D NUMBER				
				A-1 B-0	B-1 B-2	B-3 C-0	C-1 G-0	G-1
39	COPPER TUBE(G) - PROCESS		3Y5534G01	1	-	-	-	-
			3Y6759G01	-	1	1	1	1
40	VALVE COVER		3Y3051P01	1	1	1	1	1
41	CLAMP		P00752-01	2	2	2	2	2
42	TIE		P05042-01	1	1	1	1	1
43	WIRE SADDLE		428060-02	3	3	3	3	3
44	HOLDER - THERMISTOR		315479-01	1	1	1	1	1
45	TRUSS HEAD TAPPING SCREW (S-TITE)		FTS0408M0	5	5	5	5	5
46	CLIP		452254-02	2	2	2	2	2
47	INSULATION		4X8643-01	1	1	1	1	1
48	TIE		7920-0003	10	10	10	10	10
52	INSULATION TUBE		H72636A80	1	1	1	1	1
53	INSULATION - CAP		4H9594-01	1	1	1	1	1
55	BRACKET CONDENSER		425490-01	2	2	2	2	2
56	CLAMP(B) - CONDENSER		4H0622-01	4	4	4	4	4
57	PRESSURE SWITCH		459863-03	1	1	1	1	1
58	FITTING(P)		3Y0747-01	2	2	2	2	2
59	NUT (A) - FITTING		415713-03	2	2	2	2	2
60	TAPPERED PACKING		415715-01	2	2	2	2	2
61	COPPER TUBE(A-2) - HIGH SIDE		4Y7079M01	1	-	-	-	-
			4Y7834M01	-	1	1	1	1
62	COPPER TUBE(B) - HIGH SIDE		4Y7080M01	1	1	1	1	1
63	TEE		4Y4060Z01	2	2	2	2	2
64	COPPER TUBE(C) - HIGH SIDE		4Y7081M01	1	-	-	-	-
			4Y7838M01	-	1	1	1	1
65	COPPER TUBE(A) - HOT GAS		4Y7082M01	1	-	-	-	-
			4Y7835M01	-	1	1	1	1
66	BRACKET - WATER REGURATOR		4X5632-01	1	1	1	1	1
67	WATER REGULATOR		P04025-01	1	1	1	1	1
68	TUBE - CAPELLARY		4X4276-01	1	1	1	1	1
69	COPPER TUBE(A) - WATER		3Y5532G01	1	1	1	1	1
70	COPPER TUBE(B) - WATER		4Y7083G01	1	1	1	1	1
71	COPPER TUBE(C) - WATER		3Y5533G01	1	1	1	1	1
72	NYLON TIE		7920-0002	2	2	2	2	2
73	COPPER TUBE(D)-LOW SIDE	(EXCEPT 240AWNE,-21,-23 60Hz)	4Y7817M01	-	1	1	1	1
75	INSULATION TUBE		H72030300	-	1	1	1	1
76	PAN HEAD SCREW		FSP0406S0	-	2	2	2	2
77	WASHER	(240AWNE-23)	4H1365-05	4	4	4	4	4

MODEL:		TITLE: B.REFRIGERATION ASSY						
IM-240AWNE,-21,-23		【50Hz】						
INDEX NO.	DESCRIPTION	MATERIAL OR MODEL NUMBER	PART NUMBER	REQ'D NUMBER				
				G-2 J-0	J-1	J-2 K-0	K-1	K-2
1	BASE		3Y5530G01	1	1	1	1	1
2	INSULATION - BASE		4Y6898P01	1	1	1	1	1
3	PLATE - BASE		4Y0249-01	1	1	1	1	1
4	COMPRESSOR		P01855-01	1	1	1	1	1
6	RUBBER GROMMET		P01858-01	4	4	4	4	4
7	SLEEVE		P01859-01	4	4	4	4	4
8	BOLT		436206-03	4	4	4	4	4
9	CONDENSER - WATER COOLED		103099G01	1	1	1	1	1
10	FLANGE BOLT (C-TITE)		FTR0408M0	6	6	6	6	6
12	TRUSS HEAD TAPPING SCREW T2		FT20408F0	4	4	4	4	4
16	BRACKET - WATER PIPE		4Y7086M01	1	1	1	1	1
18	EVAPORATOR	(240AWNE)	2H7526G02	-	-	-	-	-
			2X2459G01	1	1	1	1	1
		(240AWNE-23)	2H1833G03	1	1	-	-	-
			2X2594G01	-	-	1	1	1
		(240AWNE-21)	208205G04	1	1	1	-	-
2X2532G01	-		-	-	1	1		
19	COLLAR		3H3879-01	4	4	4	4	4
20	SCREW EVAPORATOR	(240AWNE)	4Y4922M02	4	4	4	4	4
		(240AWNE-21,-23)	4Y4922M03	4	4	4	4	4
21	WASHER		4H0777-01	4	4	4	4	4
22	FLANGE NUT		FNHF06S0	4	4	4	4	4
23	TEE		430608-02	1	1	1	1	1
24	EXPANSION VALVE		P01874-01	1	1	1	1	1
25	COPPER TUBE (A) - LOW SIDE		3Y5353G01	1	1	1	1	1
26	COPPER TUBE (E) - HIGH SIDE		3Y5354G01	1	1	1	1	1
27	COPPER TUBE (D) - HOT GAS		3Y5355G01	1	1	1	1	1
28	TEE		420041-05	1	1	1	1	1
29	PIPE(A-1) - HIGH SIDE		4Y7836M01	1	1	1	1	1
30	TEE		420041-09	1	1	1	1	1
31	HEAT EXCHANGER		2X1238G01	1	1	1	1	1
33	DRIER		458776-01	1	1	1	1	1
34	PROCESS TUBE		4Y0273-01	1	1	1	1	1
35	HOT GAS VALVE		P04242-01	1	1	1	1	1
36	STRAINER		P00812-01	1	1	1	1	1
38	PIPE(B) - HOT GAS		4Y7012G01	1	1	1	1	1
39	COPPER TUBE(G) - PROCESS		3Y6759G01	1	1	1	1	1
40	VALVE COVER		3Y3051P01	1	1	1	1	1
41	CLAMP		P00752-01	2	2	2	2	2

MODEL:		TITLE: B.REFRIGERATION ASSY						
IM-240AWNE,-21,-23,-17		【60Hz】						
INDEX NO.	DESCRIPTION	MATERIAL OR MODEL NUMBER	PART NUMBER	REQ'D NUMBER				
				A-1 B-0	B-1 B-2	B-3 C-0	C-1 G-0	G-1
1	BASE		3Y5530G01	1	1	1	1	1
2	INSULATION - BASE		4Y6898P01	1	1	1	1	1
3	PLATE - BASE		4Y0249-01	1	1	1	1	1
4	COMPRESSOR		4A1322-01	1	1	1	-	-
			P02886-01	-	-	-	1	1
6	GROMMET		434922-02	4	4	4	-	-
	RUBBER GROMMET		P01858-01	-	-	-	4	4
7	SPACER		434921-01	4	4	4	-	-
	SLEEVE		P01859-01	-	-	-	4	4
8	BOLT		436206-04	4	4	4	-	-
			436206-03	-	-	-	4	4
9	CONDENSER - WATER COOLED		103099G01	1	1	1	1	1
10	FLANGE BOLT (C-TITE)		FTR0408M0	6	6	6	6	6
12	TRUSS HEAD TAPPING SCREW T2		FT20408F0	4	4	4	4	4
16	BRACKET - WATER PIPE		4Y7086M01	1	1	1	1	1
18	EVAPORATOR	(240AWNE)	2H7526G02	1	1	1	1	1
		(240AWNE-23)	2H1833G03	1	1	1	1	1
		(240AWNE-21)	208205G04	1	1	1	1	1
		(240AWNE-17)	2X1849G01	-	-	-	1	1
19	COLLAR		3H3879-01	4	4	4	4	4
20	SCREW EVAPORATOR	(240AWNE)	4Y4922M02	4	4	4	4	4
		(240AWNE-21) (240AWNE-23) (240AWNE-17)	4Y4922M03	4	4	4	4	4
21	WASHER		4H0777-01	4	4	4	4	4
22	FLANGE NUT		FNHF06S0	4	4	4	4	4
23	TEE		430608-02	1	1	1	1	1
24	EXPANSION VALVE		P01874-01	1	1	1	1	1
25	COPPER TUBE (A) - LOW SIDE		3Y5353G01	1	1	1	1	1
26	COPPER TUBE (E) - HIGH SIDE		3Y5354G01	1	1	1	1	1
27	COPPER TUBE (D) - HOT GAS		3Y5355G01	1	1	1	1	1
28	TEE		420041-05	1	1	1	1	1
29	PIPE(A-1) - HIGH SIDE		3Y5531M01	1	1	1	-	-
			4Y7836M01	-	-	-	1	1
30	TEE		420041-09	1	1	1	1	1
31	HEAT EXCHANGER		2X1554G01	1	1	1	1	1
33	DRIER		458776-01	1	1	1	1	1
34	PROCESS TUBE		4Y0273-01	1	1	1	1	1

MODEL:		TITLE: B.REFRIGERATION ASSY						
IM-240AWNE,-21,-23,-17		【60Hz】						
INDEX NO.	DESCRIPTION	MATERIAL OR MODEL NUMBER	PART NUMBER	REQ'D NUMBER				
				A-1 B-0	B-1 B-2	B-3 C-0	C-1 G-0	G-1
35	HOT GAS VALVE		P04242-01	1	1	1	1	1
		ONLY KOREA	P01871-01	1	1	1	1	1
36	STRAINER		P00812-01	1	1	1	1	1
38	PIPE(B) - HOT GAS		4Y7012G01	1	1	1	1	1
39	COPPER TUBE(G) - PROCESS		3Y5534G01	-	1	1	-	-
			3Y6759G01	-	-	-	1	1
40	VALVE COVER		3Y3051P01	1	1	1	1	1
41	CLAMP		P00752-01	2	2	2	2	2
42	TIE		P05042-01	1	1	1	1	1
43	WIRE SADDLE		428060-02	3	3	3	3	3
44	HOLDER - THERMISTOR		315479-01	1	1	1	1	1
45	TRUSS HEAD TAPPING SCREW (S-TITE)		FTS0408M0	5	5	5	5	5
46	CLIP		452254-02	2	2	2	2	2
47	INSULATION		4X8643-01	1	1	1	1	1
48	TIE		7920-0003	10	10	10	10	10
52	INSULATION TUBE		H72636A80	1	1	1	1	1
53	INSULATION - CAP		4H9594-01	1	1	1	1	1
55	BRACKET CONDENSER		425490-01	2	2	2	2	2
56	CLAMP(B) - CONDENSER		4H0622-01	4	4	4	4	4
57	PRESSURE SWITCH		459863-03	1	1	1	1	1
58	FITTING(P)		3Y0747-01	2	2	2	2	2
59	NUT (A) - FITTING		415713-03	2	2	2	2	2
60	TAPPERED PACKING		415715-01	2	2	2	2	2
61	COPPER TUBE(A-2) - HIGH SIDE		4Y7079M01	1	1	1	-	-
			4Y7834M01	-	-	-	1	1
62	COPPER TUBE(B) - HIGH SIDE		4Y7080M01	1	1	1	1	1
63	TEE		4Y4060Z01	2	2	2	2	2
64	COPPER TUBE(C) - HIGH SIDE		4Y7081M01	1	1	1	-	-
			4Y7838M01	-	-	-	1	1
65	COPPER TUBE(A) - HOT GAS		4Y7082M01	1	1	1	-	-
			4Y7835M01	-	-	-	1	1
66	BRACKET - WATER REGURATOR		4X5632-01	1	1	1	1	1
67	WATER REGULATOR		P04025-01	1	1	1	1	1
68	TUBE - CAPILLARY		4X4276-01	1	1	1	1	1
69	COPPER TUBE(A) - WATER		3Y5532G01	1	1	1	1	1
70	COPPER TUBE(B) - WATER		4Y7083G01	1	1	1	1	1
71	COPPER TUBE(C) - WATER		3Y5533G01	1	1	1	1	1
72	NYLON TIE		7920-0002	2	2	2	2	2

MODEL:		TITLE: B.REFRIGERATION ASSY						
IM-240AWNE,-21,-23,-17		【60Hz】						
INDEX NO.	DESCRIPTION	MATERIAL OR MODEL NUMBER	PART NUMBER	REQ'D NUMBER				
				G-2 J-0	J-1	J-2 K-0	K-1	K-2
1	BASE		3Y5530G01	1	1	1	1	1
2	INSULATION - BASE		4Y6898P01	1	1	1	1	1
3	PLATE - BASE		4Y0249-01	1	1	1	1	1
4	COMPRESSOR		P02886-01	1	1	1	1	1
6	RUBBER GROMMET		P01858-01	4	4	4	4	4
7	SLEEVE		P01859-01	4	4	4	4	4
8	BOLT		436206-03	4	4	4	4	4
9	CONDENSER - WATER COOLED		103099G01	1	1	1	1	1
10	FLANGE BOLT (C-TITE)		FTR0408M0	6	6	6	6	6
12	TRUSS HEAD TAPPING SCREW T2		FT20408F0	4	4	4	4	4
16	BRACKET - WATER PIPE		4Y7086M01	1	1	1	1	1
18	EVAPORATOR	(240AWNE)	2H7526G02	-	-	-	-	-
			2X2459G01	1	1	1	1	1
		(240AWNE-23)	2H1833G03	1	1	-	-	-
			2X2594G01	-	-	1	1	1
		(240AWNE-21)	208205G04	1	1	1	-	-
			2X2532G01	-	-	-	1	1
(240AWNE-17)	2X1849G01	1	1	1	1	1		
19	COLLAR		3H3879-01	4	4	4	4	4
20	SCREW EVAPORATOR	(240AWNE)	4Y4922M02	4	4	4	4	4
		(240AWNE-21) (240AWNE-23) (240AWNE-17)	4Y4922M03	4	4	4	4	4
21	WASHER		4H0777-01	4	4	4	4	4
22	FLANGE NUT		FNHF06S0	4	4	4	4	4
23	TEE		430608-02	1	1	1	1	1
24	EXPANSION VALVE		P01874-01	1	1	1	1	1
25	COPPER TUBE (A) - LOW SIDE		3Y5353G01	1	1	1	1	1
26	COPPER TUBE (E) - HIGH SIDE		3Y5354G01	1	1	1	1	1
27	COPPER TUBE (D) - HOT GAS		3Y5355G01	1	1	1	1	1
28	TEE		420041-05	1	1	1	1	1
29	PIPE(A-1) - HIGH SIDE		4Y7836M01	1	1	1	1	1
30	TEE		420041-09	1	1	1	1	1
31	HEAT EXCHANGER		2X1554G01	1	1	1	1	1
33	DRIER		458776-01	1	1	1	1	1
34	PROCESS TUBE		4Y0273-01	1	1	1	1	1
35	HOT GAS VALVE		P04242-01	1	1	1	1	1
		ONLY KOREA	P01871-01	1	1	1	1	1
36	STRAINER		P00812-01	1	1	1	1	1
38	PIPE(B) - HOT GAS		4Y7012G01	1	1	1	1	1

MODEL: IM-240AWNE,-21,-23,-17			TITLE: B.REFRIGERATION ASSY [60Hz]					
INDEX NO.	DESCRIPTION	MATERIAL OR MODEL NUMBER	PART NUMBER	REQ'D NUMBER				
				G-2 J-0	J-1	J-2 K-0	K-1	K-2
39	COPPER TUBE(G) - PROCESS		3Y6759G01	1	1	1	1	1
40	VALVE COVER		3Y3051P01	1	1	1	1	1
41	CLAMP		P00752-01	2	2	2	2	2
42	TIE		P05042-01	1	1	1	1	1
43	WIRE SADDLE		428060-02	3	3	3	3	3
44	HOLDER - THERMISTOR		315479-01	1	1	1	1	1
45	TRUSS HEAD TAPPING SCREW (S-TITE)		FTS0408M0	5	5	5	5	5
46	CLIP		452254-02	2	2	2	2	2
47	INSULATION		4X8643-01	1	1	1	1	1
48	TIE		7920-0003	10	10	10	10	10
52	INSULATION TUBE		H72636A80	1	1	1	1	1
53	INSULATION - CAP		4H9594-01	1	1	1	1	1
55	BRACKET CONDENSER		425490-01	2	2	2	2	2
56	CLAMP(B) - CONDENSER		4H0622-01	4	4	4	4	4
57	PRESSURE SWITCH		459863-03	1	1	1	1	1
58	FITTING(P)		3Y0747-01	2	2	2	2	2
59	NUT (A) - FITTING		415713-03	2	2	2	2	2
60	TAPPERED PACKING		415715-01	2	2	2	2	2
61	COPPER TUBE(A-2) - HIGH SIDE		4Y7834M01	1	1	1	1	1
62	COPPER TUBE(B) - HIGH SIDE		4Y7080M01	1	1	1	1	1
63	TEE		4Y4060Z01	2	2	2	2	2
64	COPPER TUBE(C) - HIGH SIDE		4Y7838M01	1	1	1	1	1
65	COPPER TUBE(A) - HOT GAS		4Y7835M01	1	1	1	1	1
66	BRACKET - WATER REGURATOR		4X5632-01	1	1	1	1	1
67	WATER REGULATOR		P04025-01	1	1	1	1	1
68	TUBE - CAPILLARY		4X4276-01	1	1	1	1	1
69	COPPER TUBE(A) - WATER		3Y5532G01	1	1	1	1	1
70	COPPER TUBE(B) - WATER		4Y7083G01	1	1	1	1	1
71	COPPER TUBE(C) - WATER		3Y5533G01	1	1	1	1	1
72	NYLON TIE		7920-0002	2	2	2	2	2
76	PAN HEAD SCREW		FSP0406S0	2	2	2	2	2
77	WASHER	(240AWNE-21)	4H1365-06	4	4	4	4	4
		(240AWNE-23)	4H1365-05	4	4	4	4	4
		(240AWNE-17)	4H1365-11	4	4	4	4	4
78	COVER		P02888-01	1	1	1	1	1
79	CLAMP		P01862-01	1	1	1	1	1
80	GASKET		P01863-01	1	1	1	1	1
81	ELBOW	(240AWNE-17)	417395-03	1	1	1	1	1
82	CONNECT PIPE	(240AWNE-17)	4Y8503G01	1	1	1	1	1

IM-240ANE (-21,-23)
IM-240AWNE(-21,-23,-17)

C. MECHANISM ASSY

(A-1) and later

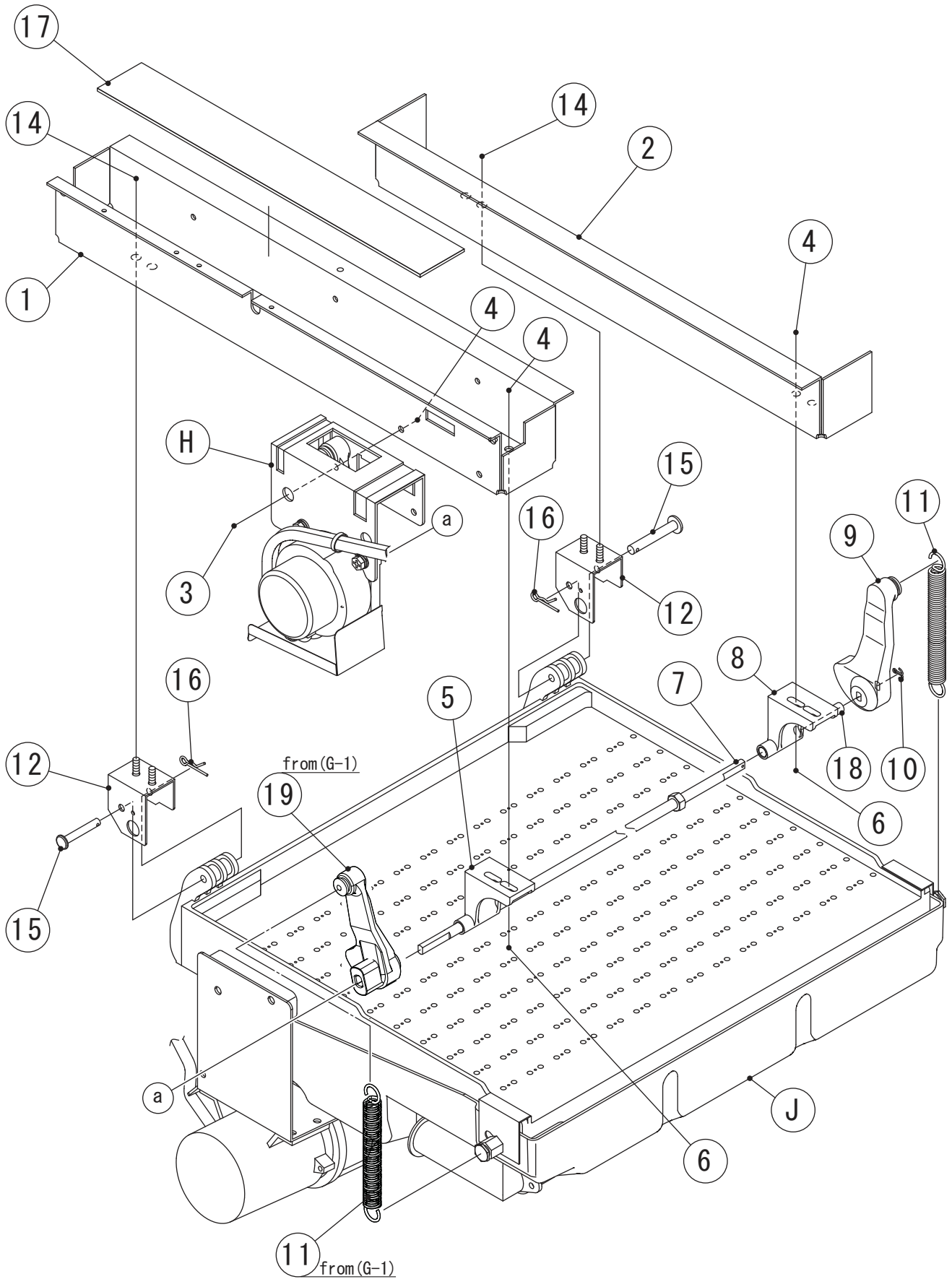

IM-240ANE (-21,-23)
IM-240AWNE(-21,-23,-17)

D. WATER CIRCUIT ASSY

(A-1) and later

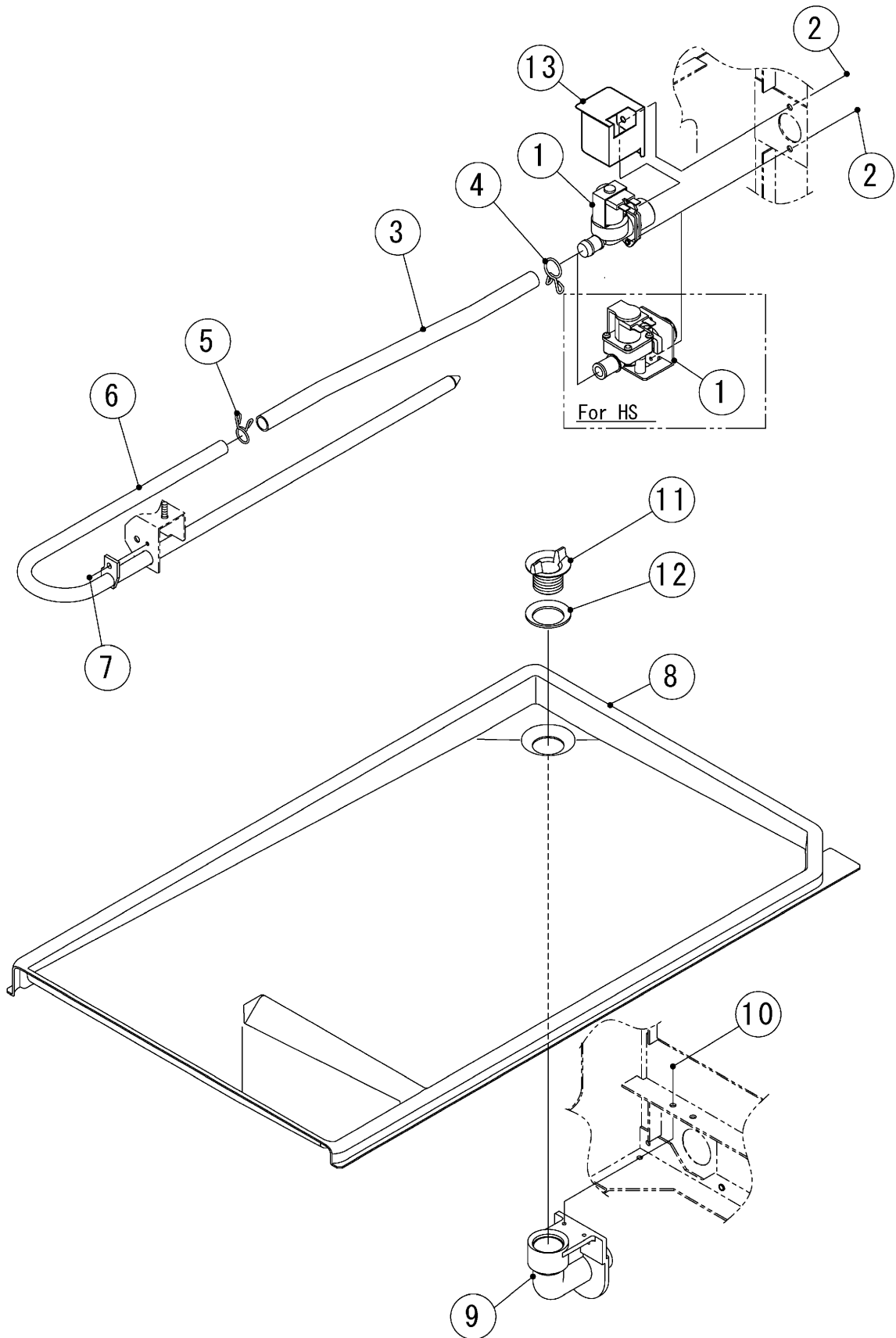

IM-240ANE (-21, -23)
IM-240AWNE (-21, -23)

50Hz (K-1) to (B-0)
60Hz (K-1) to (C-0)

E. CONTROL BOX ASSY

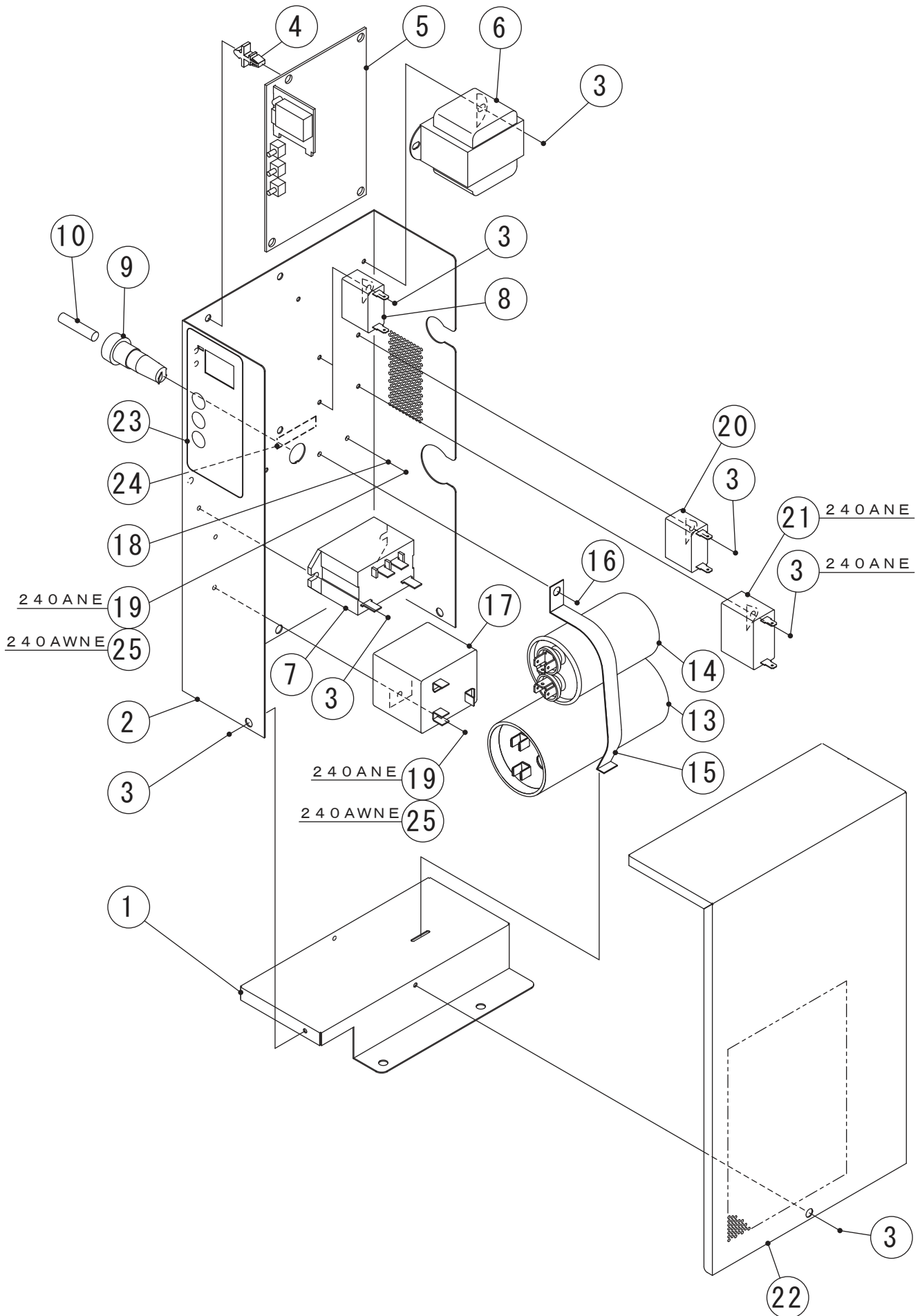

IM-240ANE (-21, -23)
IM-240AWNE (-21, -23, -17)

E. CONTROL BOX ASSY

50Hz (B-1) and later
60Hz (C-1) and later

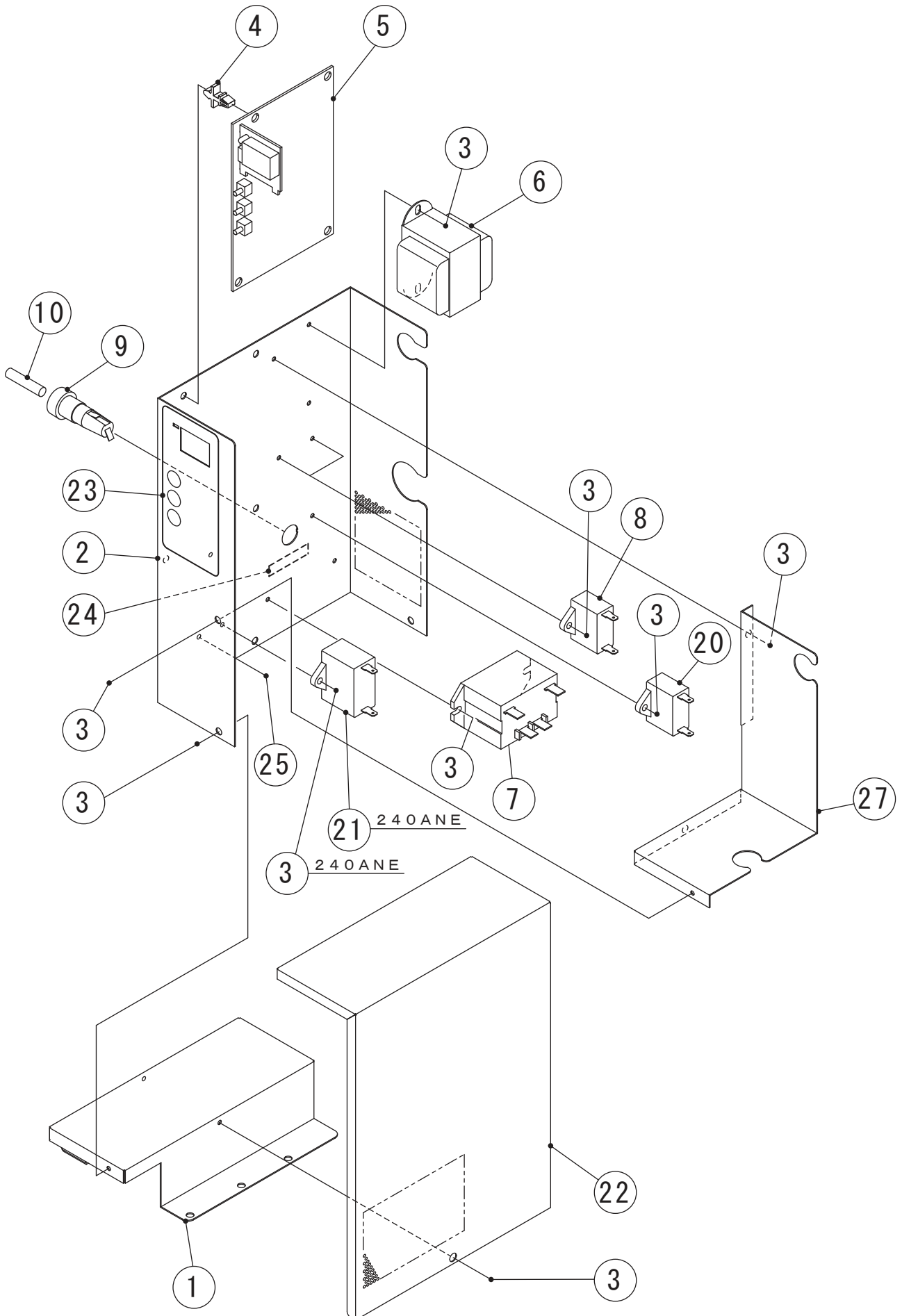

MODEL: IM-240ANE,-21,-23 IM-240AWNE,-21,-23,-17			TITLE: E.CONTROL BOX ASSY					
INDEX NO.	DESCRIPTION	MATERIAL OR MODEL NUMBER	PART NUMBER	REQ'D NUMBER				
				A-1 B-0	B-1 B-2	B-3 C-0	C-1 G-0	G-1
1	CONTROLBOX - BASE	(50Hz)	3Y5369M01	1	-	-	-	-
			3Y6722M01	-	1	1	1	1
		(60Hz)	3Y5369M01	1	1	1	-	-
			3Y6722M01	-	-	-	1	1
2	CONTROL BOX - BODY	(50Hz)	2X0230M01	1	-	-	-	-
	CONTROL BOX(B)		2X1053M01	-	1	-	-	-
	CONTROL BOX - BODY	(60Hz)	2X1251M01	-	-	1	1	1
	CONTROL BOX(B)		2X0230M01	1	1	1	-	-
3	TRUSS HEAD TAPPING SCREW T2	(240ANE,-21,-23)	FT20410F0	12	15	15	15	15
		(240AWNE,-23)(50Hz)		11	14	14	14	14
		(240AWNE,-21,-23,-17)(60Hz)		11	16	16	14	14
4	BOARD SUPPORT		P04204-01	4	4	4	4	4
5	CONTROLLER BOARD		P01873-01	1	1	1	1	1
6	TRANSFORMER		P02714-01	1	1	1	1	1
7	POWER RELAY		P00034-01	1	1	1	1	1
8	CAPACITOR		P01870-01	2	2	2	2	2
9	FUSE HOLDER	(50Hz)	P00014-01	1	1	-	-	-
			P02829-01	-	-	1	1	1
		(60Hz)	P00014-01	1	1	1	-	-
			P02829-01	-	-	-	1	1
10	FUSE	(50Hz)	P01876-01	1	1	-	-	-
			P04203-01	-	-	1	1	1
		(60Hz)	P01876-01	1	1	1	-	-
			P04203-01	-	-	-	1	1
13	START CAPACITOR	(50Hz) 3535B7C0064A250A5	3A0076-14	1	-	-	-	-
	CAPACITOR - STARTING	(60Hz)	3A0076-02	1	1	-	-	-
14	CAPACITOR - RUN	(50Hz)	3A2005-01	1	-	-	-	-
		(60Hz)	3A2005-10	1	1	-	-	-
15	BAND	(50Hz)	427254-01	1	-	-	-	-
		(60Hz)	427254-13	1	1	-	-	-
16	FLANGE BOLT (C-TITE)	(50Hz)	FTR0408M0	1	-	-	-	-
		(60Hz)		1	1	-	-	-

IM-240ANE (-21,-23)
IM-240AWNE(-21,-23,-17)

F. BIN SWITCH-2 ASSY

(A-1) and later

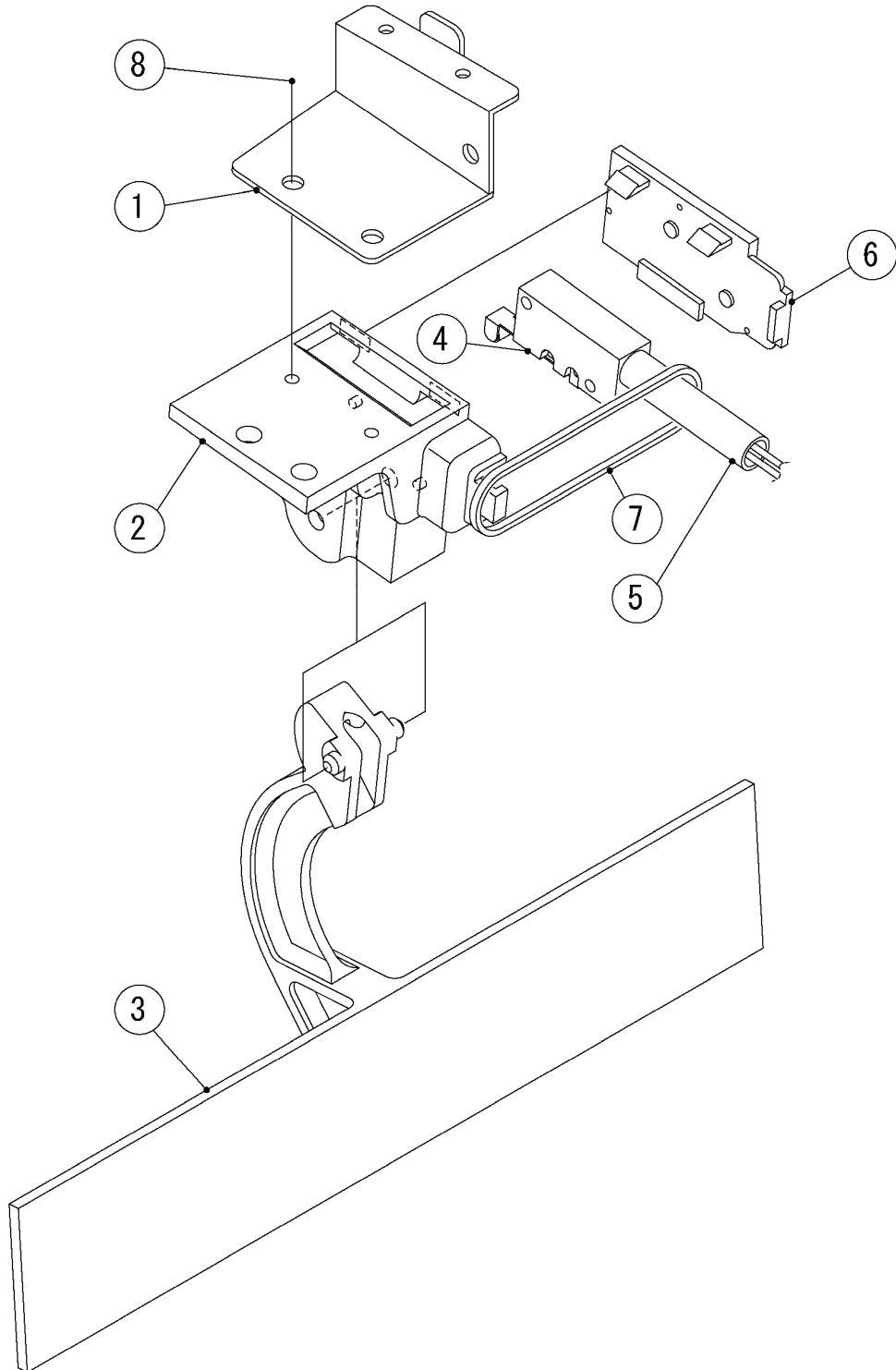

IM-240ANE (-21,-23)
IM-240AWNE(-21,-23,-17)

G. FRONT COVER ASSY

(A-1) and later

IM-240ANE

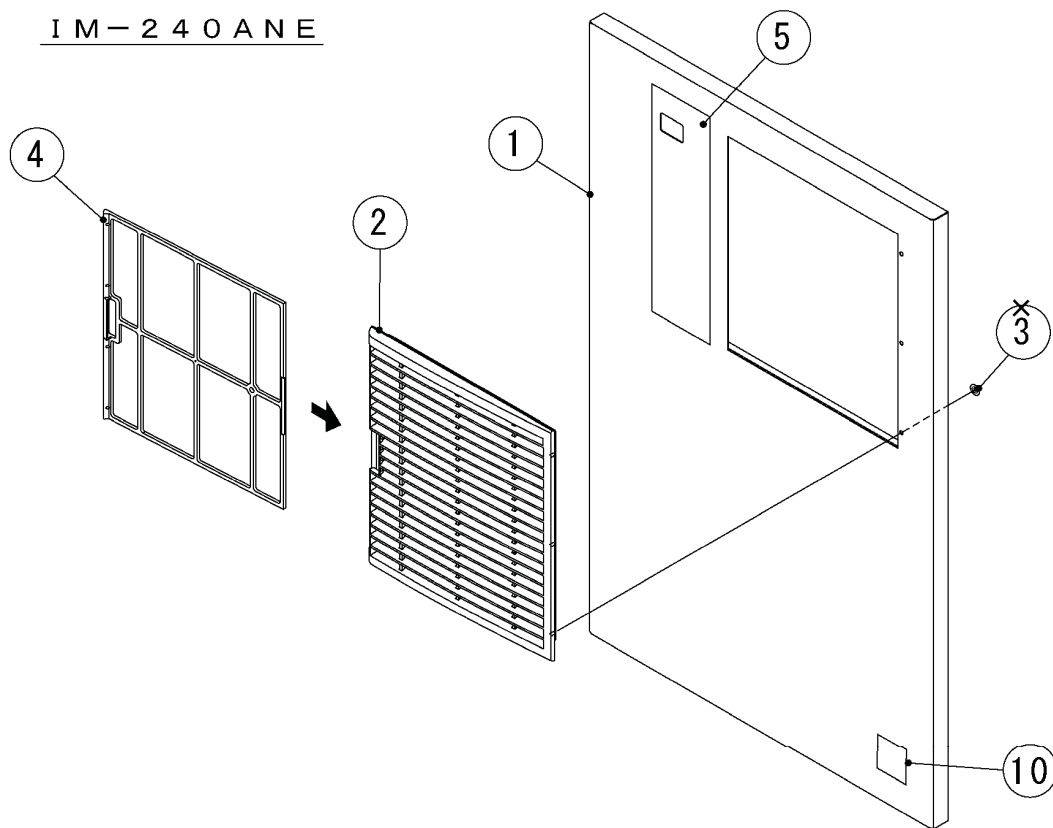

IM-240AWNE

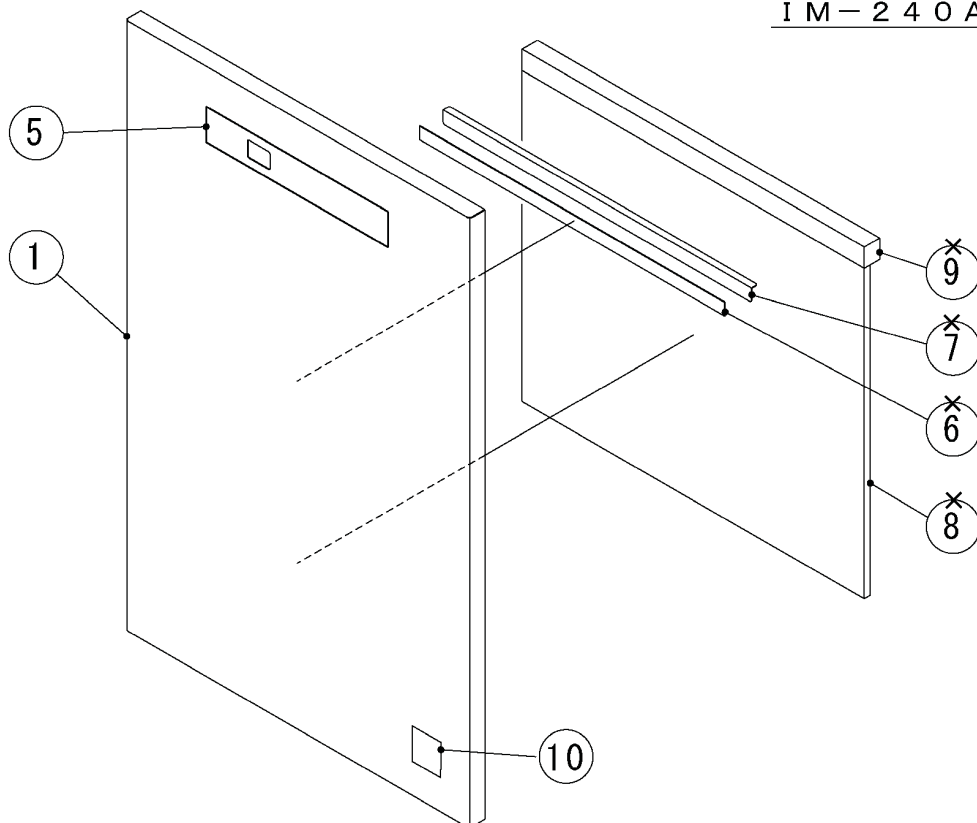

IM-240ANE (-21,-23)
IM-240AWNE(-21,-23,-17)

H. ACTUATOR MOTOR ASSY (A-1) and later

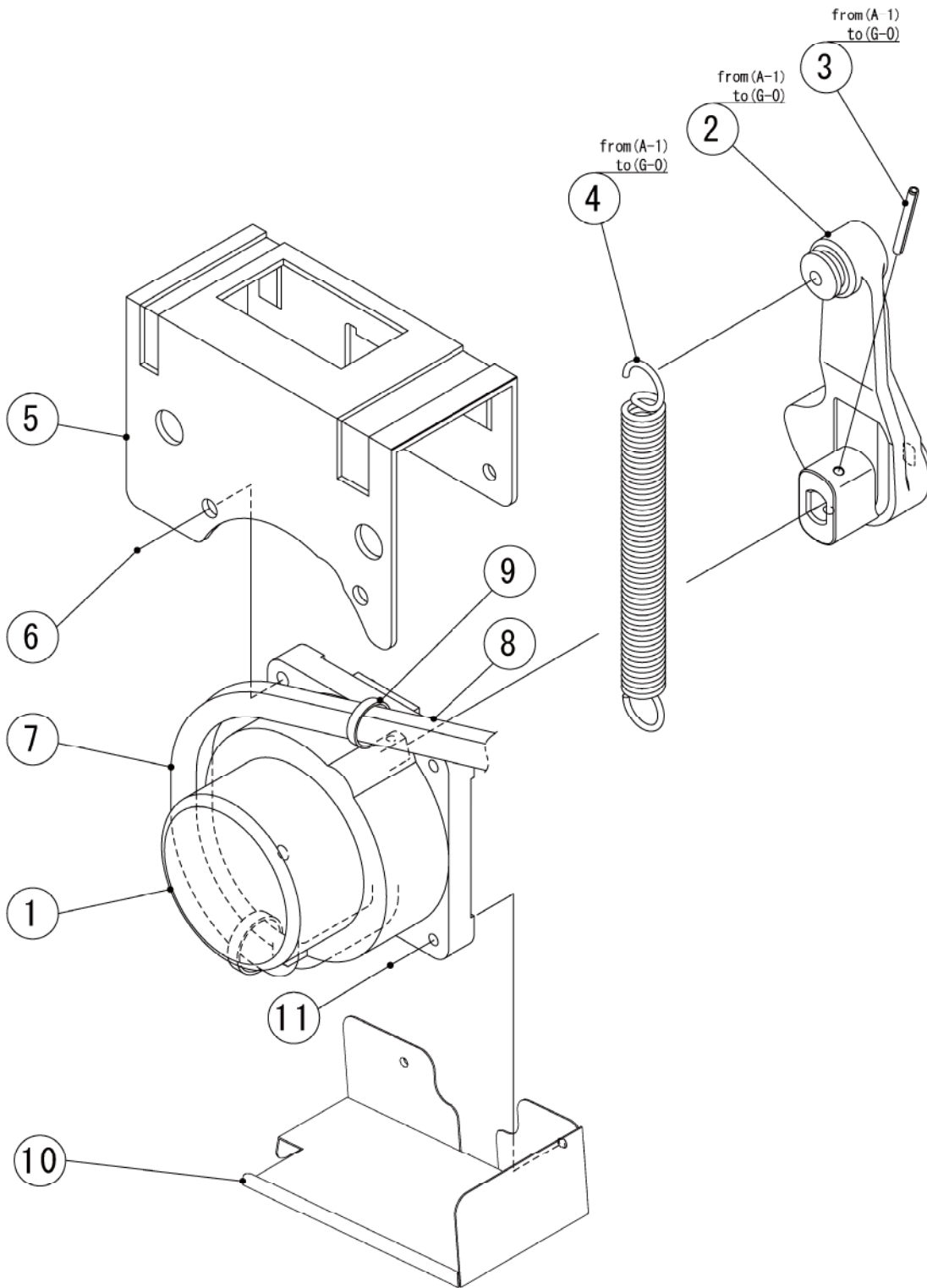

IM-240ANE (-21,-23)
IM-240AWNE(-21,-23,-17)

J. WATER PAN ASSY

(A-1) and later

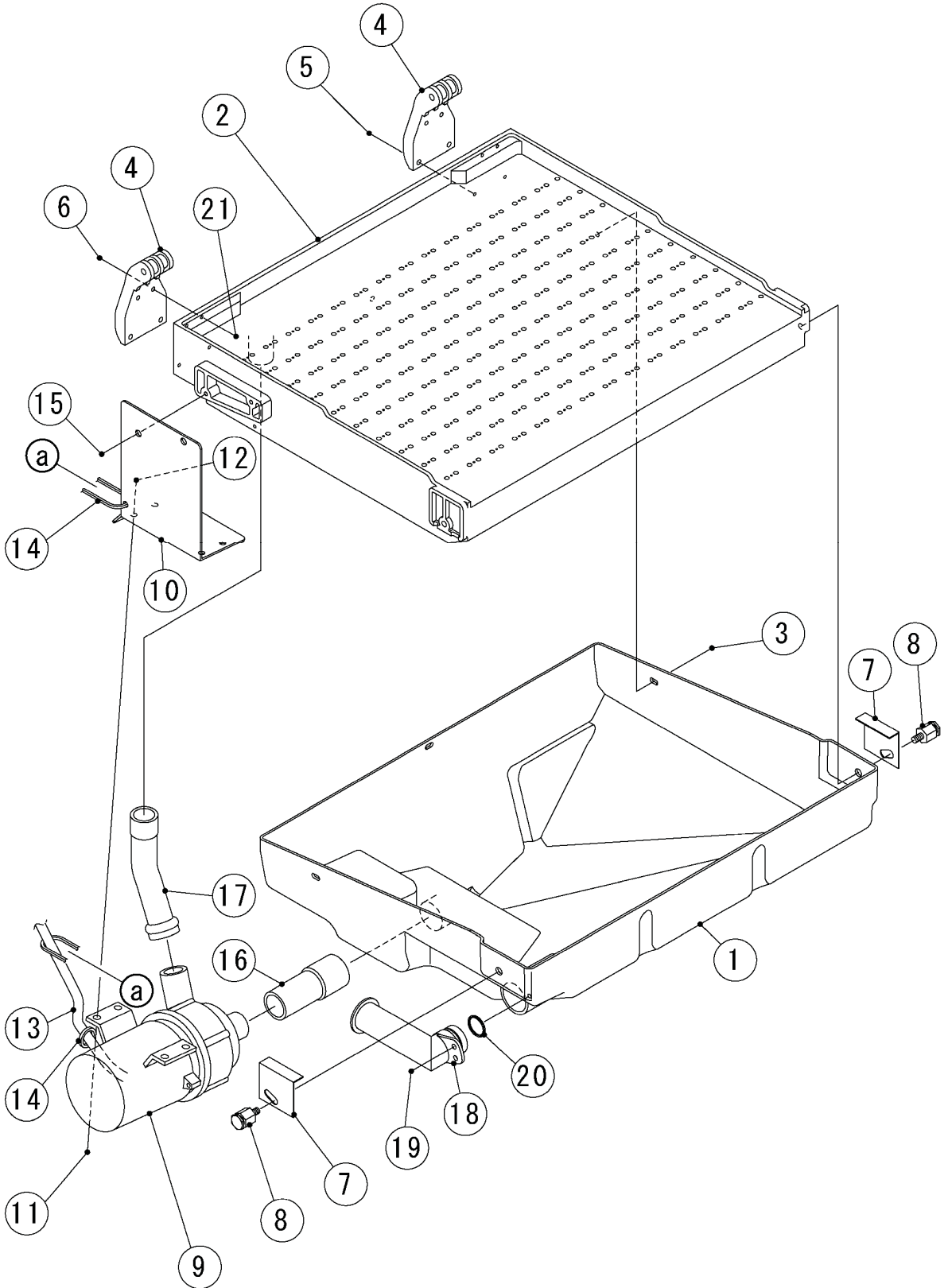

IM-240ANE (-21,-23)
IM-240AWNE(-21,-23,-17)

K. ACCESSORIES

(A-1) and later

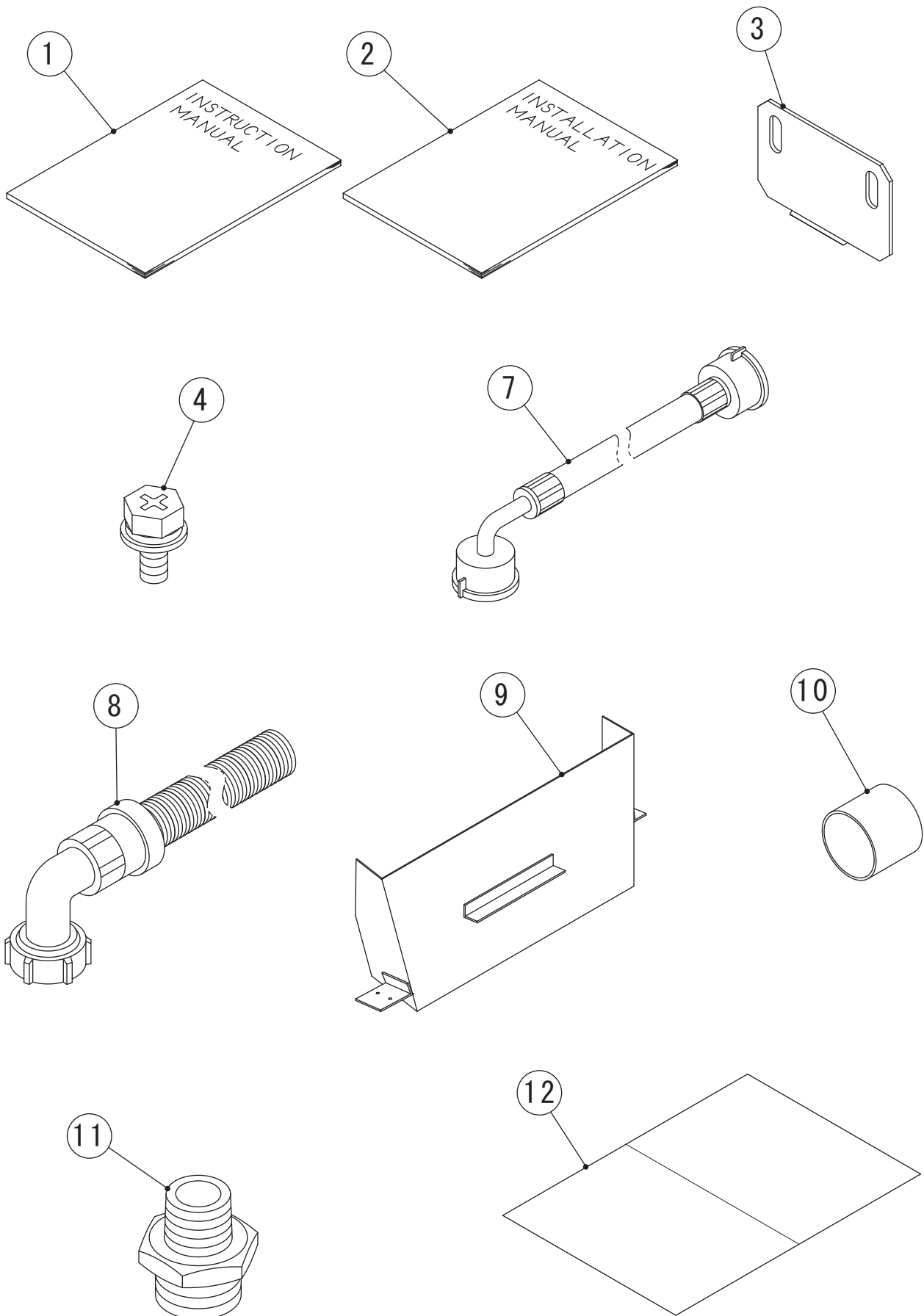

IM-240ANE (-21,-23)
IM-240AWNE (-21,-23,-17)

L. OPTIONAL PARTS

(A-1) and later

